

Instruction Manual



P6810, P6860, and P6880 Logic Analyzer Probes

071-1059-01

There are no current European directives that apply to this product. This product provides cable and test lead connections to a test object of electronic measuring and test equipment.

Warning

The servicing instructions are for use by qualified personnel only. To avoid personal injury, do not perform any servicing unless you are qualified to do so. Refer to all safety summaries prior to performing service.

www.tektronix.com

Copyright © Tektronix, Inc. All rights reserved.

Tektronix products are covered by U.S. and foreign patents, issued and pending. Information in this publication supercedes that in all previously published material. Specifications and price change privileges reserved.

Tektronix, Inc., P.O. Box 500, Beaverton, OR 97077

TEKTRONIX and TEK are registered trademarks of Tektronix, Inc. MagniVu, iView, PatGenVu, PowerFlex, QuickStart, and TLAVu are unregistered trademarks of Tektronix, Inc.

WARRANTY

Tektronix warrants that the products that it manufactures and sells will be free from defects in materials and workmanship for a period of one (1) year from the date of shipment. If a product proves defective during this warranty period, Tektronix, at its option, either will repair the defective product without charge for parts and labor, or will provide a replacement in exchange for the defective product.

In order to obtain service under this warranty, Customer must notify Tektronix of the defect before the expiration of the warranty period and make suitable arrangements for the performance of service. Customer shall be responsible for packaging and shipping the defective product to the service center designated by Tektronix, with shipping charges prepaid. Tektronix shall pay for the return of the product to Customer if the shipment is to a location within the country in which the Tektronix service center is located. Customer shall be responsible for paying all shipping charges, duties, taxes, and any other charges for products returned to any other locations.

This warranty shall not apply to any defect, failure or damage caused by improper use or improper or inadequate maintenance and care. Tektronix shall not be obligated to furnish service under this warranty a) to repair damage resulting from attempts by personnel other than Tektronix representatives to install, repair or service the product; b) to repair damage resulting from improper use or connection to incompatible equipment; c) to repair any damage or malfunction caused by the use of non-Tektronix supplies; or d) to service a product that has been modified or integrated with other products when the effect of such modification or integration increases the time or difficulty of servicing the product.

THIS WARRANTY IS GIVEN BY TEKTRONIX IN LIEU OF ANY OTHER WARRANTIES, EXPRESS OR IMPLIED. TEKTRONIX AND ITS VENDORS DISCLAIM ANY IMPLIED WARRANTIES OF MERCHANTABILITY OR FITNESS FOR A PARTICULAR PURPOSE. TEKTRONIX' RESPONSIBILITY TO REPAIR OR REPLACE DEFECTIVE PRODUCTS IS THE SOLE AND EXCLUSIVE REMEDY PROVIDED TO THE CUSTOMER FOR BREACH OF THIS WARRANTY. TEKTRONIX AND ITS VENDORS WILL NOT BE LIABLE FOR ANY INDIRECT, SPECIAL, INCIDENTAL, OR CONSEQUENTIAL DAMAGES IRRESPECTIVE OF WHETHER TEKTRONIX OR THE VENDOR HAS ADVANCE NOTICE OF THE POSSIBILITY OF SUCH DAMAGES.

Table of Contents

| | |
|-------------------------------------|------------|
| General Safety Summary | vii |
| Preface | ix |
| Related Documentation | ix |
| Commonly Used Terms | x |
| Contacting Tektronix | xii |

Operating Basics

| | |
|--|-------------|
| Product Description | 1-1 |
| P6810 General Purpose Probe | 1-1 |
| P6810 Leadset Adapters and Accessories | 1-3 |
| P6860 High-Density Probe | 1-4 |
| P6880 High-Density Differential Probe | 1-6 |
| Mictor-on-PCB to P6860 Compression Adapter | 1-7 |
| Compression-on-PCB to P6434 Mictor Adapter | 1-8 |
| Attaching Probe Labels | 1-10 |
| Connecting the Probes to the Logic Analyzer | 1-11 |
| Cleaning the P6860 and P6880 Compression Footprints | 1-12 |
| Cleaning the P6860 and P6880 Probe Heads | 1-12 |
| Storing the P6860 and P6880 Probe Heads | 1-13 |
| Connecting the Probes to the Target System | 1-14 |
| Connecting the P6810 General Purpose Probe | 1-14 |
| Connecting the P6860 High Density and P6880 Differential Probes | 1-16 |
| Installing the Correct Elastomer Holder | 1-16 |
| Connecting the Mictor-on-PCB to P6860 Compression Adapter (Applies to P6860 Probe Only) | 1-18 |
| Connecting the Compression-on-PCB to P6434 Mictor Adapter | 1-18 |

Reference

| | |
|---|------------|
| Designing an Interface Between the P6810, P6860, and P6880 Probes and a Target System | 2-1 |
| Signal Fixturing Considerations | 2-1 |
| Signal Names | 2-6 |
| Land Footprints | 2-21 |
| Mechanical Considerations | 2-26 |
| Physical Attachment Requirements for the P6810 Probe | 2-29 |
| Physical Attachment Requirements for the P6860 and P6880 Probes | 2-30 |
| Physical Attachment Requirements for the Compression-on-PCB to P6434 Mictor and Mictor-on-PCB to P6860 Compression Adapters | 2-32 |
| Electrical Considerations | 2-32 |

| | |
|---|------|
| Transmission Lines | 2-32 |
| P6810 General Purpose Probe Load Model | 2-33 |
| P6860 High-Density and P6880 High-Density Differential Probes Load Model | 2-35 |

Specifications

| | |
|---|------------|
| Mechanical and Electrical Specifications | 3-1 |
|---|------------|

Maintenance

| | |
|---------------------------------------|------------|
| Probe Calibration | 4-1 |
| Service Strategy | 4-1 |
| Functional Check | 4-1 |
| Inspection and Cleaning | 4-2 |
| Repackaging Instructions | 4-2 |

Replaceable Parts

| | |
|--|------------|
| Parts Ordering Information | 5-1 |
| Using the Replaceable Parts List | 5-1 |
| Mfr. Code to Manufacturer Cross Index | 5-2 |

Index

List of Figures

| | |
|--|------|
| Figure i: Differential input amplitude | x |
| Figure ii: Probe example | xii |
| | |
| Figure 1-1: P6810 General Purpose probe | 1-2 |
| Figure 1-2: P6810 probe leadset adapters and accessories | 1-4 |
| Figure 1-3: P6860 High-Density probe | 1-5 |
| Figure 1-4: P6880 High-Density Differential probe | 1-6 |
| Figure 1-5: Mictor-on-PCB to P6860 Compression adapter | 1-8 |
| Figure 1-6: Compression-on-PCB to P6434 Mictor adapter | 1-9 |
| Figure 1-7: Clearance for probe connection using Compression-on-PCB to P6434 Mictor adapter | 1-10 |
| Figure 1-8: Connecting the probes to the logic analyzer | 1-11 |
| Figure 1-9: Cleaning the probe heads | 1-13 |
| Figure 1-10: Storing the probe heads | 1-14 |
| Figure 1-11: Connecting the P6810 probe to the target system | 1-15 |
| Figure 1-12: Press-in Nuts installation | 1-16 |
| Figure 1-13: Connecting the P6860 and P6880 probes to the target system | 1-17 |
| | |
| Figure 2-1: P6810 General-Purpose probe land footprint | 2-22 |
| Figure 2-2: P6860 High-Density probe land footprint | 2-23 |
| Figure 2-3: High-Density probe land footprint in a typical pass-through signal path layout configuration | 2-24 |
| Figure 2-4: Example layouts of the High-Density compression compared to the mictor land footprints | 2-24 |
| Figure 2-5: P6880 Differential probe land footprint | 2-25 |
| Figure 2-6: High-Density Differential probe land footprint in a typical pass-through signal path layout configuration | 2-26 |
| Figure 2-7: Land footprint requirements for the P6860 and P6880 probes (top view) | 2-27 |
| Figure 2-8: Land footprint requirements for the Compression-on-PCB to P6434 Mictor adapter | 2-29 |
| Figure 2-9: Physical attachment requirements for the P6810 probe | 2-30 |
| Figure 2-10: Nut Bar design | 2-31 |
| Figure 2-11: Press-in Nut design | 2-32 |
| Figure 2-12: Single podlet load model | 2-33 |

| | |
|---|-------------|
| Figure 2-13: Eight-channel leadset (barrel connectors) | 2-34 |
| Figure 2-14: Eight-channel differential leadset | 2-34 |
| Figure 2-15: High-Density and High-Density Differential probe load model | 2-35 |
| Figure 2-16: Mictor-on-PCB to Compression adapter load model . | 2-36 |
| Figure 2-17: Compression-on-PCB to P6434 Mictor adapter load model | 2-36 |
| | |
| Figure 5-1: P6810 General Purpose probe accessories | 5-3 |
| Figure 5-2: P6860 High-Density probe accessories | 5-4 |
| Figure 5-3: P6880 High-Density Differential probe accessories | 5-5 |
| Figure 5-4: Optional accessories | 5-6 |

List of Tables

| | |
|--|-------------|
| Table 2-1: Logic analyzer clock and qualifier availability | 2-2 |
| Table 2-2: 2X Demultiplexing source-to-destination channel assignments | 2-4 |
| Table 2-3: 4X Demultiplexing source-to-destination channel assignments | 2-5 |
| Table 2-4: P6810 Probe signal connections on 136 and 102 channel modules for probe #4 and probe #3 | 2-7 |
| Table 2-5: Probe signal connections on 102 and 136 channel modules for probe #2 and probe #1 | 2-8 |
| Table 2-6: P6810 Probe signal connections on 68 and 34 channel modules | 2-9 |
| Table 2-7: P6860 High-Density Probe channel mapping on 136 and 102 channel modules | 2-10 |
| Table 2-8: P6860 High-Density Probe channel mapping on 68 and 34 channel modules | 2-11 |
| Table 2-9: P6880 High-Density Differential Probe channel mapping on 136 and 102 channel modules for probe #4 and probe #3 | 2-12 |
| Table 2-10: P6880 High-Density Differential Probe channel mapping on 136 and 102 channel modules for probe #2 and probe #1 | 2-13 |
| Table 2-11: P6880 High-Density Differential Probe channel mapping on 68 and 34 channel modules | 2-14 |
| Table 2-12: Recommended Compression-on-PCB to P6434 Mictor adapter and Mictor-on-PCB to Compression adapter channel mapping for 136 and 102 channel modules | 2-15 |
| Table 2-13: Recommended Compression-on-PCB to P6434 Mictor adapter and Mictor-on-PCB to Compression adapter channel mapping for 68 channel module | 2-17 |
| Table 2-14: Recommended Compression-on-PCB to P6434 Mictor adapter and Mictor-on-PCB to Compression adapter channel mapping for 34 channel module | 2-19 |
| Table 2-15: Characteristics | 2-33 |
| Table 3-1: Electrical and mechanical specifications | 3-1 |
| Table 3-2: Environmental specifications | 3-2 |

General Safety Summary

Review the following safety precautions to avoid injury and prevent damage to this product or any products connected to it. To avoid potential hazards, use this product only as specified.

Only qualified personnel should perform service procedures.

While using this product, you may need to access other parts of the system. Read the *General Safety Summary* in other system manuals for warnings and cautions related to operating the system.

To Avoid Fire or Personal Injury

Connect and Disconnect Properly. Connect the probe output to the measurement instrument before connecting the probe to the circuit under test. Disconnect the probe input and the probe ground from the circuit under test before disconnecting the probe from the measurement instrument.

Observe All Terminal Ratings. To avoid fire or shock hazard, observe all ratings and markings on the product. Consult the product manual for further ratings information before making connections to the product.

Do not apply a potential to any terminal, including the common terminal, that exceeds the maximum rating of that terminal.

Avoid Exposed Circuitry. Do not touch exposed connections and components when power is present.

Do Not Operate With Suspected Failures. If you suspect there is damage to this product, have it inspected by qualified service personnel.

Do Not Operate in Wet/Damp Conditions.

Do Not Operate in an Explosive Atmosphere.

Keep Product Surfaces Clean and Dry.

Provide Proper Ventilation. Refer to the manual's instructions for details on installing the product so it has proper ventilation.

Symbols and Terms

Terms in this Manual. These terms may appear in this manual:



WARNING. *Warning statements identify conditions or practices that could result in injury or loss of life.*



CAUTION. *Caution statements identify conditions or practices that could result in damage to this product or other property.*

Terms on the Product. These terms may appear on the product:

DANGER indicates an injury hazard immediately accessible as you read the marking.

WARNING indicates an injury hazard not immediately accessible as you read the marking.

CAUTION indicates a hazard to property including the product.

Symbols on the Product. The following symbols may appear on the product:



CAUTION
Refer to Manual

Preface

This document provides information on using and servicing the P6810, P6860, and P6880 Logic Analyzer Probes.

Related Documentation

In addition to these probe instructions, the following documentation is available for your Tektronix 700 Series Logic Analyzers.

- The *Tektronix Logic Analyzer Family User Manual* provides overall user information for the TLA Series Logic Analyzer.
- The *TLA7Axx Module Service Manual* that provides module-level service information for major components of the TLA Series Logic Analyzer.
- *P6810 General Purpose Logic Analyzer Probe Label Instructions*
- *P6860 High Density Logic Analyzer Probe Label Instructions*
- *P6880 High Density Differential Logic Analyzer Probe Label Instructions*
- The online help provides information about the user interface, the TLA700 Programmatic Interface (TPI), and the TLAScript interface. To view the online help, select Help Topics from the Help menu. The TLAScript online help provides links to related topics in TPI.
- The online release notes provide last-minute product and software information not included in this manual. To access the Probe Manual Release Notes, click Start > Programs > Tektronix Logic Analyzer > TLA Release Notes.
- A series of microprocessor support instruction manuals provide operating and service instructions for the individual microprocessor support packages.
- The *TLA7QS QuickStart Training Manual* provides training exercises to help you learn key features of the logic analyzer. The training manual is designed to be used with the TLA7QS QuickStart training board.
- The *P6434 Mass Termination Probe Instructions* provides instructions for using the P6434 Probes with older Tektronix logic analyzers.
- The *P6417 & P6418 Logic Analyzer Probes Instructions* provides instructions for using the P6417 and P6418 Probes.

Commonly Used Terms

Refer to the following list of commonly used terms throughout the manual.

Compression footprint A connectorless, solderless contact between your PCB and the P6860 and P6880 Probes. Connection is obtained by applying pressure between your PCB and the probe through a Z-axis elastomer.

Differential input amplitude definition For differential signals, the magnitude of the difference voltage $\bar{V}_{\max} - V_{\min}$ (and $V_{\min} - \bar{V}_{\max}$) must be greater than or equal to 150 mV. Refer to Figure i.

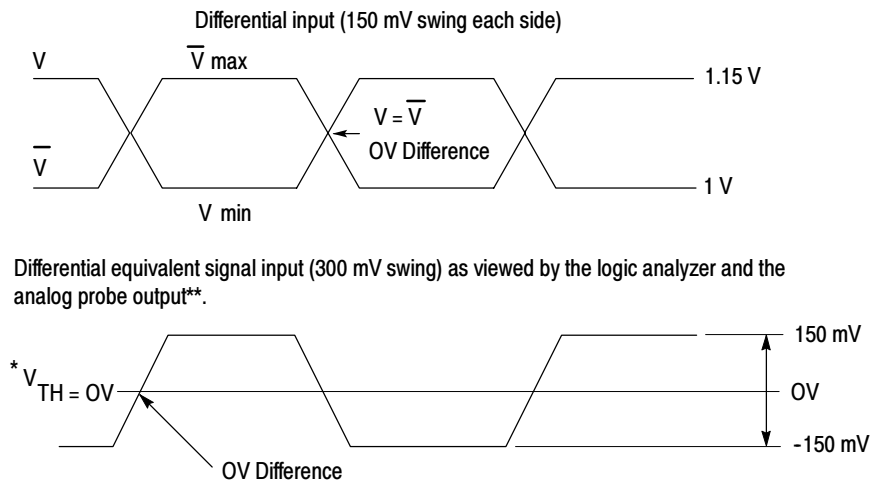

* Note: For differential inputs, the module threshold should be set to OV (assuming no common mode error).

** Note: See online help for further analog output details.

Figure i: Differential input amplitude

Functional check procedure Functional check procedures verify the basic functionality of the probes by confirming that the probes recognize signal activity at the probe tips.

Keepout area The area of the printed circuit board in which only probe components may be mounted.

Module The unit that plugs into a mainframe which provides instrument capabilities such as logic analysis.

Module end The end of the probe which plugs into the module unit.

- PCB** An acronym for Printed Circuit Board; also known as Etched Circuit Board (ECB).
- Podlet** A circuit contained in a flex lead and attached to a probe which provides square-pin connections to the circuit under test for one data acquisition channel and a reference pin.
- Podlet holder** A removable clip that groups eight individual podlets into a single 8-wide P6810 Probe assembly. This provides ease when connecting to a row of 2 x 8 2.54 mm (0.100 in) square pins.
- Probe** The device that connects a module with a target system.

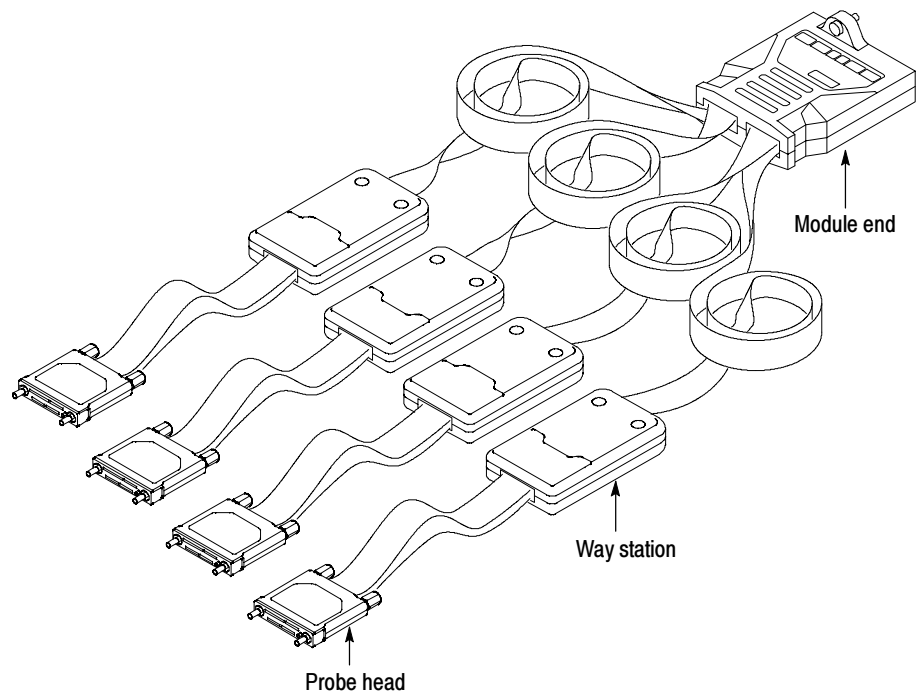

Figure ii: Probe example

- Probe adapter** A device that connects the LA module probe to a target system.
- Probe head** The end of the probe (see Figure ii) that connects to the target system or probe adapter.

| | |
|-------------------------|--|
| SMT KlipChip | An interface device for attaching logic analyzer probes to components with a maximum lead diameter of 2.413 mm (0.095 in) and a stackable on lead centers of 1.27 mm (0.050 in). |
| Way station | An intermediate probe part (see Figure ii) used to connect the heads of the P6810 and P6880 Probes to a single ribbon cable. |
| Z-axis elastomer | Silicone-based material containing vertical wires that conduct only in the z-axis. |

Contacting Tektronix

| | |
|--------------------------|---|
| Phone | 1-800-833-9200* |
| Address | Tektronix, Inc. Department or name (if known) 14200 SW Karl Braun Drive P.O. Box 500 Beaverton, OR 97077 USA |
| Web site | www.tektronix.com |
| Sales support | 1-800-833-9200, select option 1* |
| Service support | 1-800-833-9200, select option 2* |
| Technical support | Email: techsupport@tektronix.com 1-800-833-9200, select option 3* 6:00 a.m. - 5:00 p.m. Pacific time |

* **This phone number is toll free in North America. After office hours, please leave a voice mail message. Outside North America, contact a Tektronix sales office or distributor; see the Tektronix web site for a list of offices.**



Operating Basics

Operating Basics

This section provides a brief description of the Tektronix P6810, P6860, and P6880 Logic Analyzer Probes and adapters, information on attaching color-coded probe labels, and probe and adapter connection instructions from the logic analyzer to the target system.

Product Description

The P6810, P6860, and P6880 Logic Analyzer Probes connect a TLA7Axx Series Logic Analyzer module to a target system. Each probe consists of 34 channels. You can connect the P6810 Probe to the target system through podlet holders or leadsets. In addition, a variety of leadsets, SMT KlipChips and adapters aid in your connection to the target system. The P6860 Probe can be connected through the use of the compression land pattern or a Mictor connector via the Compression-on-PCB to P6434 to Mictor adapter. The P6880 probe is designed for connection to the compression land pattern only configured for differential signals. The P6880 is not compatible with either the Mictor-on-PCB to P6860 Probe adapter or the Compression-on-PCB to P6434 Probe adapter.

P6810 General Purpose Probe

The P6810 Probe is a 34-channel, general purpose probe (see Figure 1-1).

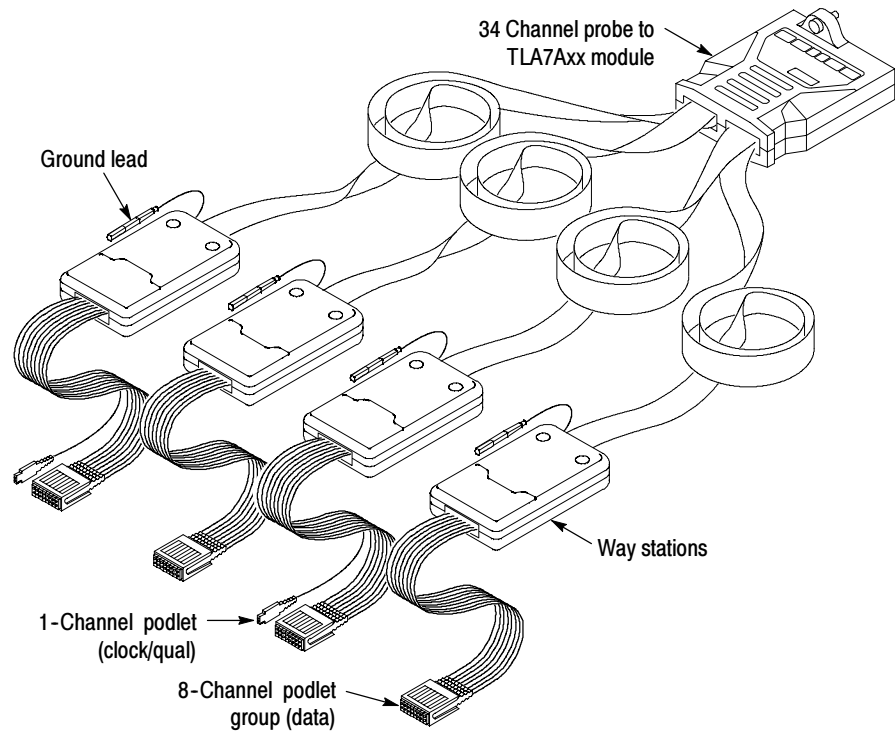

Figure 1- 1: P6810 General Purpose probe

NOTE. Remember to connect the ground lead of the way station to the target system to improve signal integrity.

The following list details the capabilities and qualities of the P6810 Probe:

- 34 individual active channel podlets
- Differential and single-ended data, clock and qualification inputs
- 2 mm (0.079 in) and 2.54 mm (0.1 in) podlet and leadset connection capability
- Maximum non-destructive input voltage
- Leadset support for both single-ended and differential applications
- Podlet holder for 8-channel applications
- Color-coded signal connectors
- -2.5 V to +5 V input operating range
- -2.0 V to +4.5 V threshold range
- 300 mV minimum single-ended signal amplitude

- 150 mV amplitude each side minimum differential signal
- Minimal loading of <1 pF and 20 k Ω to ground

NOTE. *Single podlet input capacitance is 0.7 pF, but in a group, each podlet will have 1 pF input capacitance.*

P6810 Leadset Adapters and Accessories

Leadsets enhance flexible access to the target system signals by allowing single-pin podlet connections of signals and grounds. This allows the separation of ground and signal connections, providing flexible access to the PCB and backplane connections where signals are not easily accessible together. The following leadsets and accessories accompany the P6810 General Purpose Probe.

- **1-Channel single-ended and differential leadset.** Supports individual leadset connections to backplanes and other connection points requiring single-ended 2 mm (0.079 in) and 2.54 mm (0.1 in) connections. Both leads contain damping resistors in the lead tips.
- **8-Channel single-ended leadset.** Supports individual leadset connections to backplanes and other multiple, dense, single-end connections in a 2 mm (0.079 in) and/or 2.54 mm (0.1 in) pin array. One common ground connection for all input signals. The positive leads contain damping resistors and the leadset housing contains a damping resistor in the ground path of each channel.
- **8-Channel differential leadset.** Supports individual leadset connections to backplanes and other multiple, dense, differential connections in a 2 mm (0.079 in) and/or 2.54 mm (0.1 in) pin array. Individual + and - leads for each differential signal input. All leads contain damping resistors in the lead tips.
- **SMT KlipChip.** An interface device for attaching logic analyzer probes to components with a maximum lead diameter of 2.413 mm (0.095 in) and a stackable on lead center of 1.27 mm (0.050 in).
- **Podlet holders.** Removable clip that groups eight individual podlets into a single 8-wide probe assembly. This provides ease when connecting to a row of 2 x 8 2.54 mm (0.1 in) square pins.

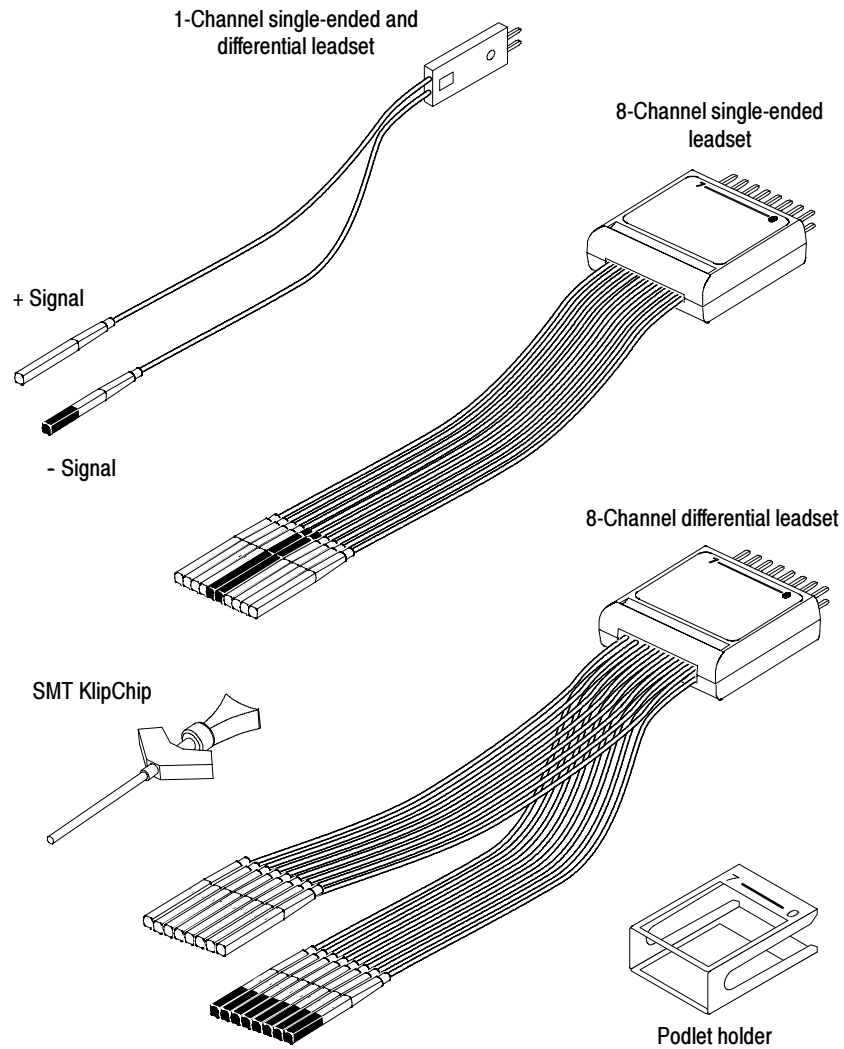

Figure 1-2: P6810 probe leadset adapters and accessories

P6860 High-Density Probe

The P6860 Probe is a 34-channel, high-density probe (see Figure 1-3) consisting of two independent probe heads of 17 channel connectors each (16 data and 1 clock/qual).

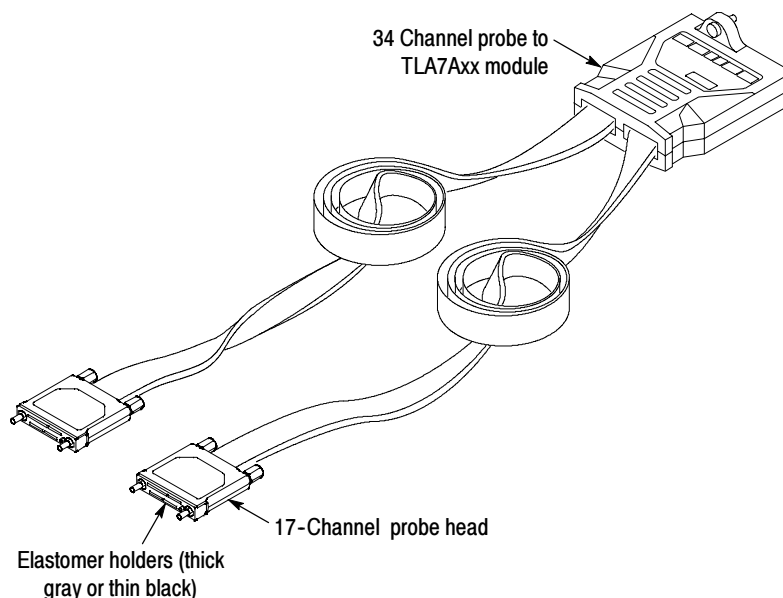

Figure 1-3: P6860 High-Density probe

The following list details the capabilities and qualities of the P6860 Probe:

- Differential or single-ended clock and qualification inputs
- Single-ended data inputs
- Compression contact eliminates need for built-in connector
- Land pattern supports direct signal pass-through
- Supports PCB thickness of 1.27 mm to 6.35 mm (0.050 in to 0.250 in)
- Consists of two independent probe heads of 17 channels each (16 data and 1 clock/qual)
- Narrow 17-channel probe head makes for easier placement and layout
- 2X mode, (for example, 1:2 demultiplexing) uses single-probe head
- 4X mode, (for example, 1:4 demultiplexing) uses one-half of the probe head
- Similar channel density to current Mictor connectors
- Color-coded keyed signal connectors
- Adapter supports Mictor-based connections
- -2.5 V to +5 V input operating range
- -2.0 V to +4.5 V threshold range

- 300 mV minimum single-ended signal amplitude
- 150 mV amplitude each side minimum differential signal
- Minimal loading of 0.7 pF @ 20 k Ω to ground loading

P6880 High-Density Differential Probe

The P6880 Probe is a 34-channel, high-density differential probe (see Figure 1-4) consisting of four independent probe heads of 8/9 channels each.

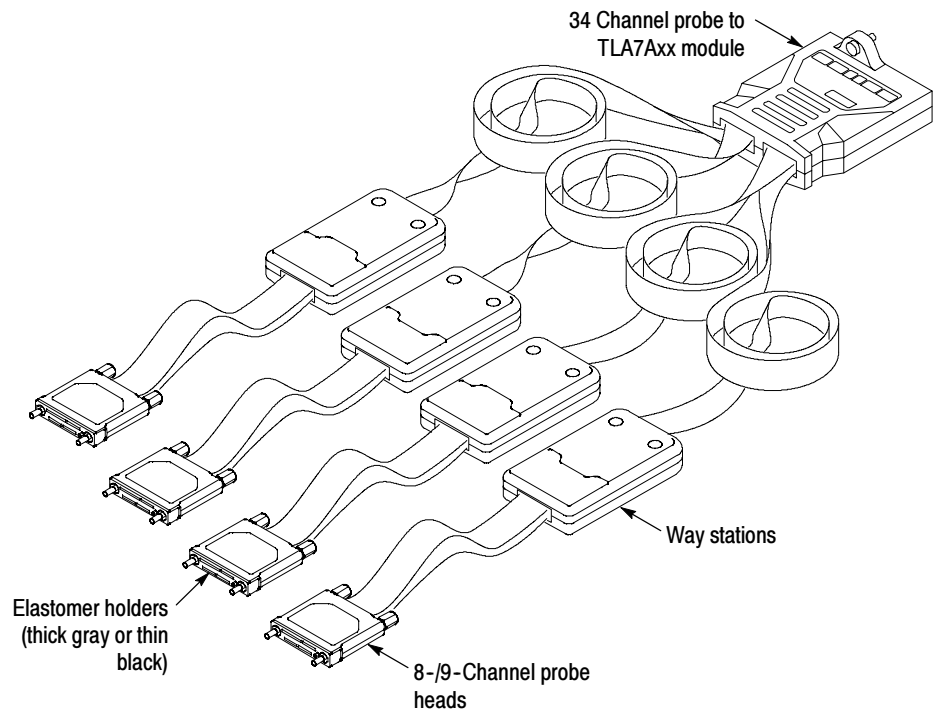

Figure 1-4: P6880 High-Density Differential probe

The following list details the capabilities and qualities of the P6880 Probe:

- High-density probe mechanical packaging at half the channel density in the probe head
- Differential data, clock and qualification inputs (single-ended signals may be probed if negative input is grounded)
- Same compression land pattern as High-Density Probe eliminates need for built-in connector
- Land pattern supports direct signal pass-through

- Supports PCB thickness of 1.27 mm to 6.35 mm (0.050 in to 0.250 in)
- Consists of four probe heads supporting 8/9 channels each (nine with clock/qual) for a total of 34 channels
- 2X mode (1:2 demultiplexing) and 4X mode (1:4 demultiplexing), use two and one probe head(s) respectively to minimize required board real estate
- Color-coded keyed signal connectors
- -2.5 V to +5 V input operating range
- -2.0 V to +4.5 V threshold range
- 300 mV minimum single-ended signal amplitude
- 150 mV each side minimum differential signal amplitude
- Minimal loading of 0.7 pF @ 20 k Ω to ground loading

Mictor-on-PCB to P6860 Compression Adapter

The Mictor-on-PCB to P6860 Compression adapter (see Figure 1-5) allows existing microprocessor support packages and your hardware designs with embedded Mictor connectors to be connected to the P6860 High-Density Probe.

The CLK pin on the Mictor is connected to the CLK+ pin of the compression footprint. The CLK- pin of the compression footprint is tied to ground. This allows the differential clock input of the P6860 probe to function as a single-ended signal.

This adapter supports standard Mictor connector footprints and signal connections on older logic analyzer designs.

Differential qualification and clock signals are not supported through the Mictor-on-PCB to Compression adapter due to Mictor footprint limitations (only + side of clock and qual signals are supported).

The Mictor adapter adds 2.7 pF to the high-density compression probe load of 0.7 pF for a combined adapter and probe capacitance load of 3.4 pF.

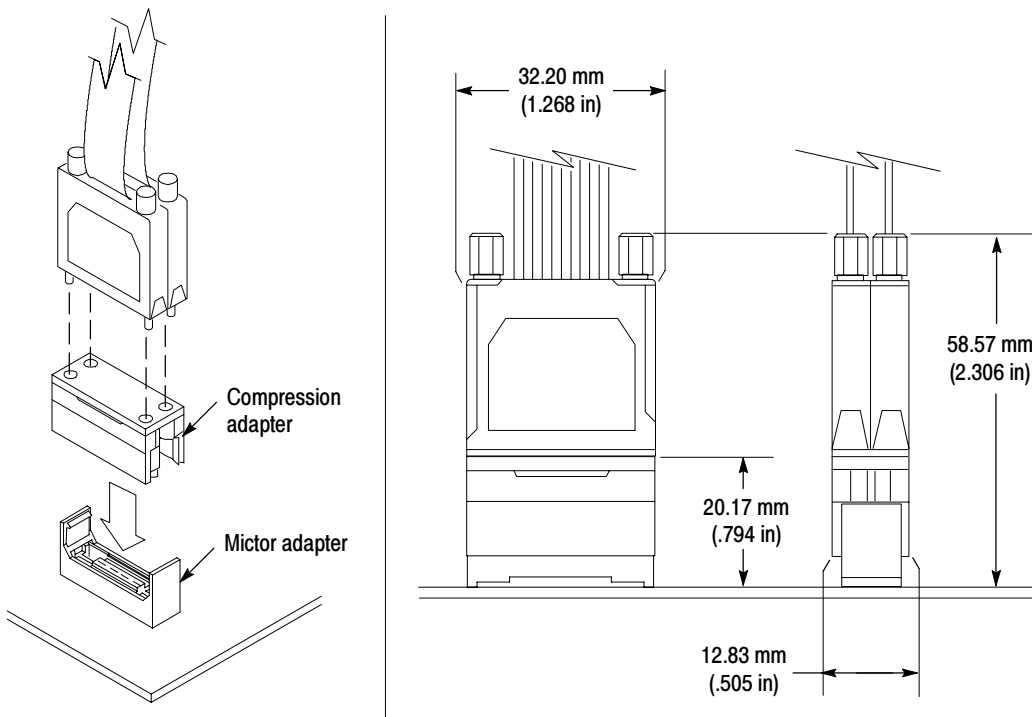

Figure 1-5: Mictor-on-PCB to P6860 Compression adapter

See Figure 1-7 on page 1-10 for comparing the clearances between the P6434 and P68xx probe adapters.

Compression-on-PCB to P6434 Mictor Adapter

The Compression-on-PCB to P6434 Mictor adapter (see Figure 1-6) allows the TLA6xx and TLA7Lx/Mx/Nx/Px/Qx logic analyzers using a P6434 Probe to take advantage of the new compression footprint and eliminate the need for Mictor connectors in your target system.

NOTE. To use the P6434 adapter, do not install press-in nuts. However, if board thickness is > .093 in, you will need to install press-in nuts before migrating to P68xx probes.

Two different screw lengths are required to accommodate the 1.27 mm to 6.35 mm (0.050 in to 0.250 in) PCB thickness range.

This adapter requires the use of the Compression-on-PCB to P6434 Mictor adapter land footprint. See Figure 2-8 for further dimensional information.

The Compression-on-PCB to Mictor adapter adds 1.5 pF to the P6434 probe load of 2.0 pF for a combined adapter and probe capacitance load of 3.5 pF.

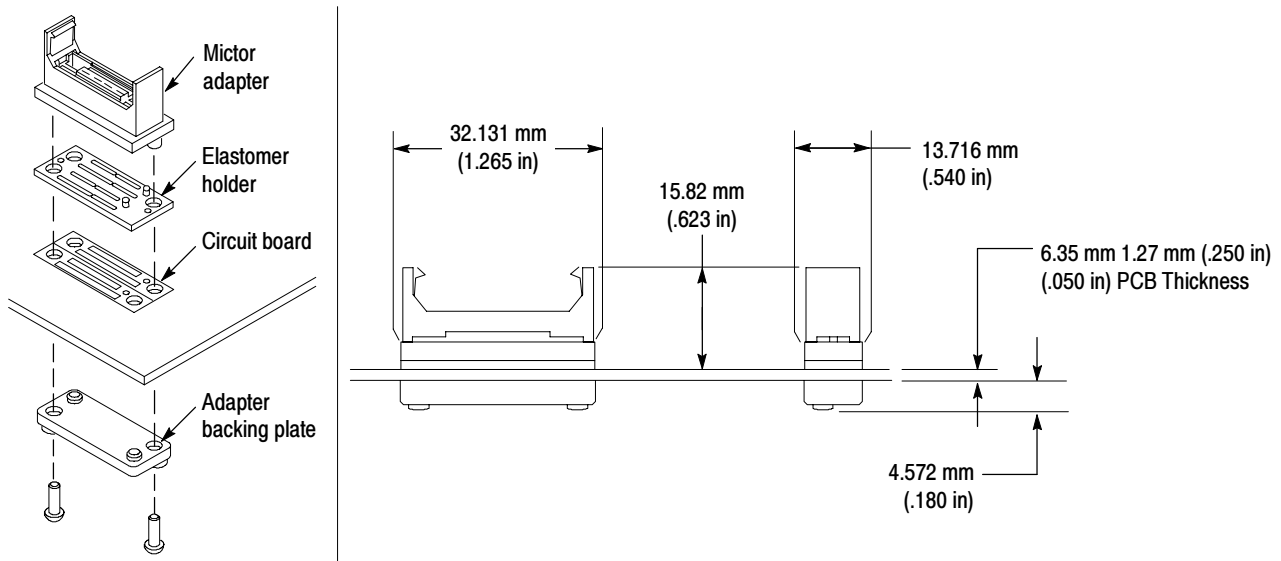

Figure 1-6: Compression-on-PCB to P6434 Mictor adapter

To compare the clearance between the P6434 Probe connection and the P6434 Probe connection via the Compression-on-PCB to P6434 Mictor adapter refer to Figure 1-7. Note that the difference in clearance between the P6434 Probe connection and the P6434 Probe connection using the Compression-on-PCB to P6434 Mictor adapter is 3.68 mm (0.145 in).

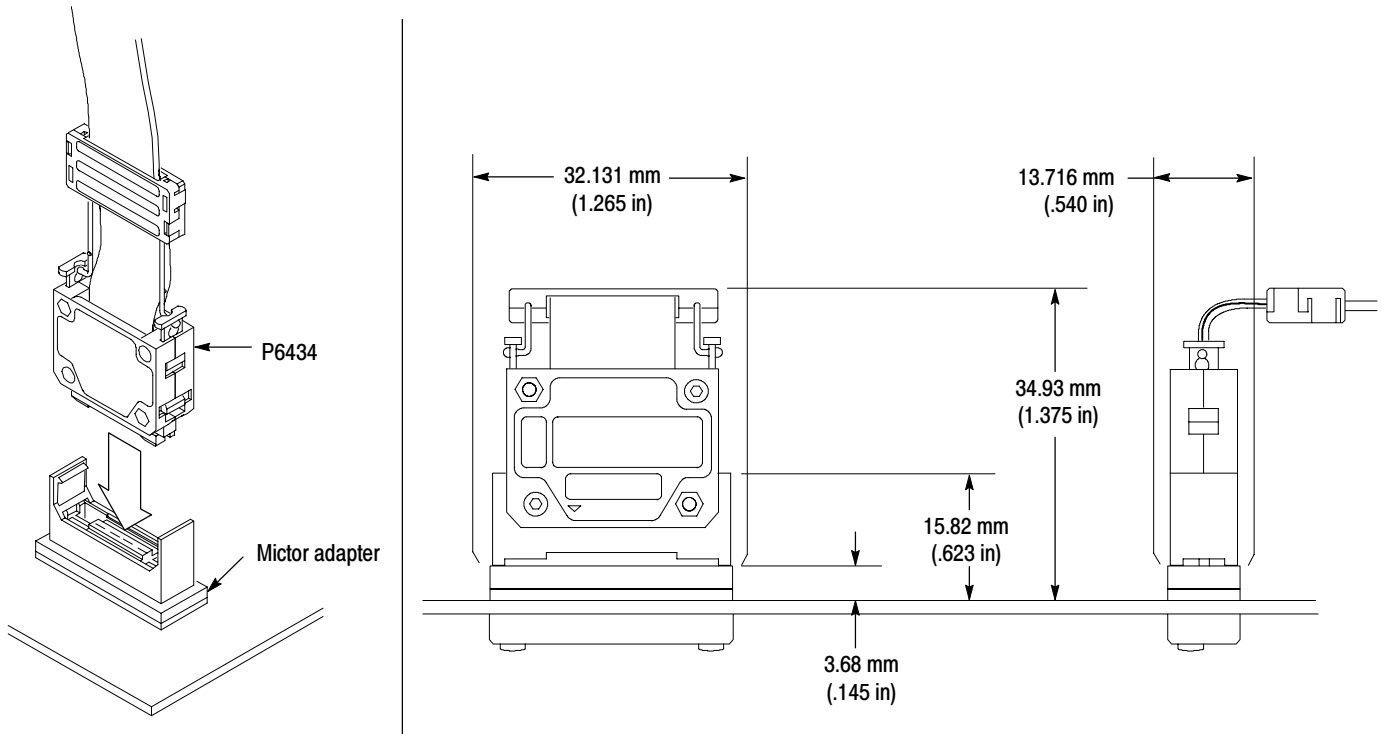

Figure 1-7: Clearance for probe connection using Compression-on-PCB to P6434 Mictor adapter

Attaching Probe Labels

When you purchase a TLA7Axx logic analyzer module, you receive the probes with all labels already attached.

However, if you purchase additional probes for the logic analyzer module, you will need to apply the color-coded labels. You will find a detailed description of how to attach the labels in the following instructions:

- *P6810 General Purpose Logic Analyzer Probe Label Instructions*
- *P6860 High Density Logic Analyzer Probe Label Instructions*
- *P6880 High Density Differential Logic Analyzer Probe Label Instructions*

Connecting the Probes to the Logic Analyzer

Refer to Figure 1-8 and connect the probes to the logic analyzer according to the following steps.

1. Identify the beveled edges of the connector inside the module end of the probe.
2. Align the beveled edges of the connector to its mating connector on the logic analyzer module and press into place.
3. Use care to evenly tighten both screws on the module end of the probe until they are snug. First slightly tighten both screws, then snug each screw to 4 in-lbs (max).

NOTE. All P68xx series Logic Analyzer probes can be connected to the logic analyzer when it is powered up. In addition, all P68xx series Logic Analyzer probes connect to the logic analyzer in exactly the same manner.

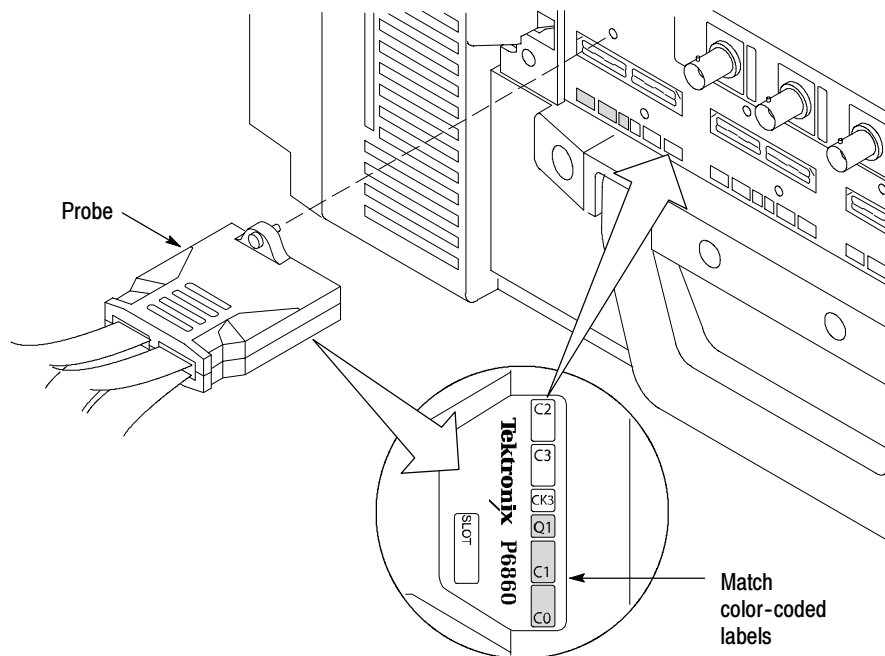

Figure 1-8: Connecting the probes to the logic analyzer

Cleaning the P6860 and P6880 Compression Footprints



CAUTION. *To avoid electrical damage, always turn off the power of your target system before cleaning the compression footprint.*

Prior to connecting the probe to the target system, the compression footprints on the your board must be properly cleaned. Clean the compression footprints according to the following steps:

1. Use a lint-free cloth moistened with isopropyl alcohol and gently wipe the footprint surface.
2. Remove any remaining lint using a nitrogen air gun.

NOTE. *Use alcohol sparingly and be sure that you have removed any remaining lint or residue with the nitrogen air gun.*

Cleaning the P6860 and P6880 Probe Heads

Before connecting the P6860 and P6880 Probes to the target system, ensure that the probe heads are free from dust, dirt, and contaminants. If necessary, clean the probe heads according to the following steps.



CAUTION. *Static discharge can damage semiconductor components in the probe head. Always wear a grounded antistatic wrist strap whenever handling the probe head. Also verify that anything to which the probe head is connected does not carry a static charge.*

NOTE. *Never clean the elastomers. Always replace them instead. Refer to the Replaceable Parts section of this manual for information on ordering parts.*

1. Remove elastomer holder.
2. Moisten a cotton swab with isopropyl alcohol.

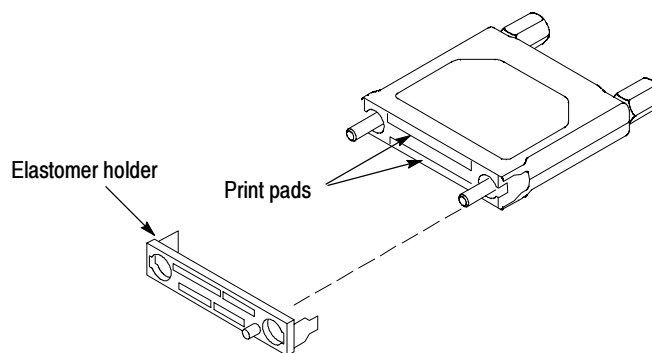

Figure 1-9: Cleaning the probe heads

3. Gently wipe the edge print pads of the hybrid.
4. Remove any remaining lint using a nitrogen air gun.
5. Put the elastomer holder back in place.



CAUTION. *Be careful not to touch the elastomers to avoid damaging the probe contacts.*

Storing the P6860 and P6880 Probe Heads

To protect the elastomer, it is important to properly store the probe heads when the probes are not in use. See Figure 1-10.

1. Locate the keying pin on the probe end and align it to the keying pin hole on the nut bar.
2. While holding the probe end at a perpendicular angle to the nut bar, loosely attach both probe head screws.

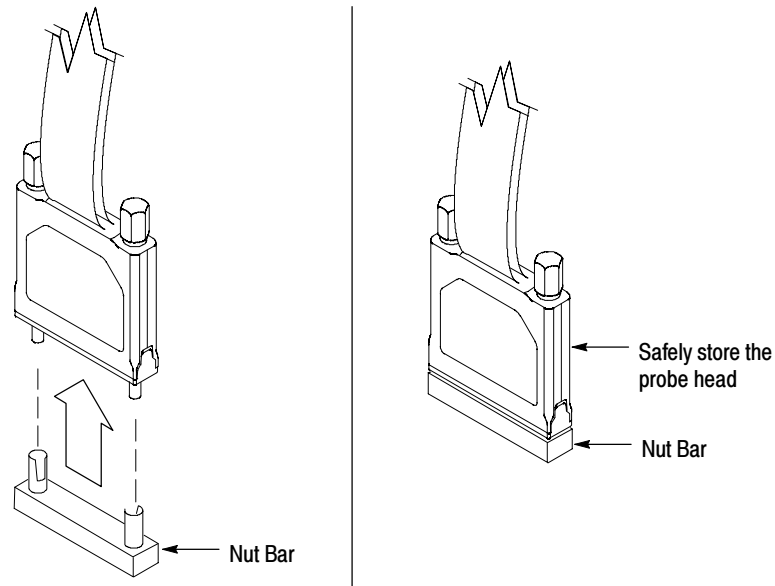

Figure 1-10: Storing the probe heads

Connecting the Probes to the Target System

Connecting the P6810 General Purpose Probe

Refer to Figure 1-11 and connect the probe to the target system by performing the steps that follow. You can connect the probe heads to the target system without turning off the power to the target system.



CAUTION. To avoid damaging the probe and target system, always position the probe at a perpendicular angle to the mating connector and then connect the probe. Incorrect handling of the probe while connecting it to the target system can result in damage to the probe or to the mating connector in the target system.

1. Connect the probe end to the square pins on the PCB.
2. If using the single-ended leadset, connect the negative input to ground on the PCB.
3. If using the differential leadset, connect the positive side of the podlet to the positive side of the signal on the PCB, and the negative side of the podlet to the negative side of the signal.
4. Connect the way station ground to ground on the PCB.

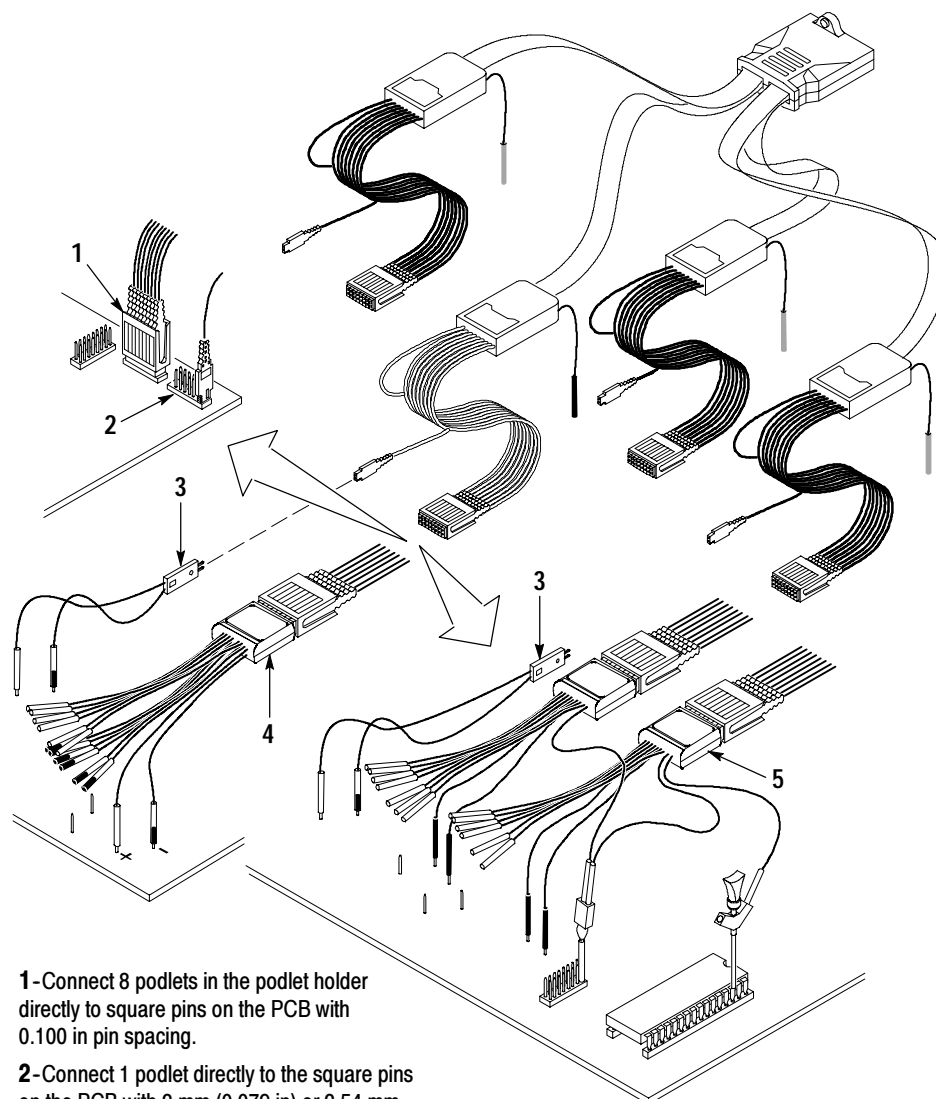

1 - Connect 8 podlets in the podlet holder directly to square pins on the PCB with 0.100 in pin spacing.

2 - Connect 1 podlet directly to the square pins on the PCB with 2 mm (0.079 in) or 2.54 mm (0.100 in) pin spacing.

3 - Connect 1 podlet with 1 channel leadset to the square pin on the PCB with 2 mm (0.079 in) or 2.54 mm (0.100 in) pin spacing. The negative lead (half-white/half-black housing that contains a damping resistor) is connected to ground in a single-ended application lead or the minus in a differential application.

4 - Connect 8 podlets in the podlet holder with an 8 channel differential leadset to the square pins on the PCB with 2 mm (0.079 in) or 2.54 mm (0.100 in) pin spacing. The negative lead (half-white/half-black housing that contains a damping resistor) is connected to the minus in a differential application.

5 - Connect 8 podlets in the podlet holder with an 8 channel single-ended leadset to the square pins on the PCB with 2 mm (0.079 in) or 2.54 mm (0.100 in) pin spacing. The negative lead (total black housing that contains no damping resistor; however, the leadset housing contains a damping resistor in ground path for each channel) is connected to ground in a single-ended application lead.

Figure 1-11: Connecting the P6810 probe to the target system

Connecting the P6860 High Density and P6880 Differential Probes

Connect the P6860 High-Density and P6880 Differential Probes (see Figure 1-13) to the target system. You can connect the probes to the target system without turning off the power to the target system.

Installing the Correct Elastomer Holder. If the PCB is $\leq .093$ in, use the thin elastomer holder with the nut bar. If the PCB is $> .093$ in, use the thick elastomer holder with the press-in nuts.

■ Nut Bar

1. Press the nut bar backing plate into the two holes on the underside of the compression footprint on the PCB.
2. Locate the keying pin on the probe end and align it to the keying pin hole on the PCB.
3. While holding the probe end at a perpendicular angle to the PCB, finger-tighten both probe head screws until snug, not to exceed 1 in-lbs.



CAUTION. When attaching the probe head to the target system, you must use care to evenly tighten probe head screws until they are snug. First tighten both screws until the nut bar makes contact with the board surface, then snug each screw to 1 in-lbs (max). Under tightening the probe head screws can result in intermittence. Over tightening can result in damage to the elastomer holder and stripped screws.

■ Press-in Nuts

1. Install the press-in nuts on the PCB by following the Manufacturer's installation procedure. Refer to Figure 1-12 for press-in nut installation details.

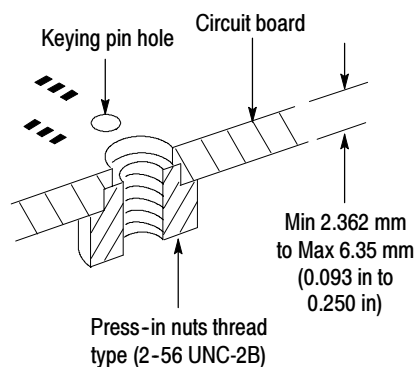

Figure 1-12: Press-in Nuts installation

2. Locate the keying pin on the probe end and align it to the keying pin hole on the PCB.
3. While holding the probe end at a perpendicular angle to the PCB, finger tighten both probe head screws until snug, not to exceed 1 in-lbs.



CAUTION. When attaching the probe head to the target system, you must use care to evenly tighten probe head screws until they are snug. First slightly tighten both screws, then snug each screw to 1 in-lbs (max). Under tightening the probe head screws can result in intermittence. Over tightening can result in damage to the elastomer holder and stripped screws.

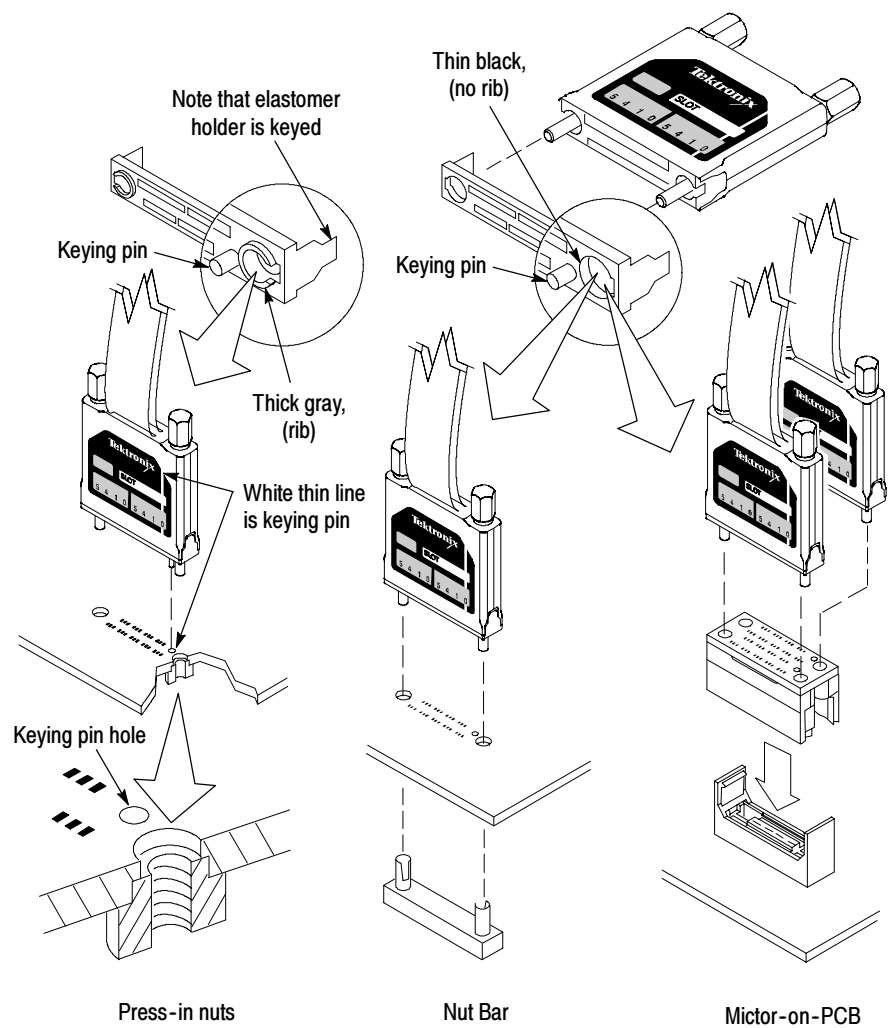

Figure 1-13: Connecting the P6860 and P6880 probes to the target system

**Connecting the
Mictor-on-PCB to P6860
Compression Adapter
(Applies to P6860 Probe
Only)**

The Mictor-on-PCB to P6860 Compression adapter (see Figure 1-5 on page 1-8) allows existing applications of older logic analyzer modules and probes to connect to the compression footprint. You can connect the adapter to the target system without turning off the target system. Connect the adapter according to the following steps.

NOTE. *Be sure to use the thin elastomer holder. A thin elastomer is black and does not have the protruding rib (see Figure 1-13).*

1. While holding the first probe end at a perpendicular angle to the adapter, place the probe end into the adapter and finger-tighten the screws until snug, not to exceed 1 in.-lbs.
2. Connect the second probe end to the adapter in the same manner.
3. Press the connected probe ends and adapter into the existing Mictor connector on the PCB.

This adapter supports standard Mictor connector footprints and signal connections on older logic analyzer designs.

The differential qualification and clock signals are not supported through the Mictor-on-PCB to P6860 Compression adapter due to the Mictor footprint limitations (only + side of clock and qual signals are supported).

The Mictor adapter adds 2.7 pF to the high-density compression probe load of 0.7 pF for a combined adapter and probe capacitance load of 3.4 pF.

**Connecting the
Compression-on-PCB to
P6434 Mictor Adapter**

The Compression-on-PCB to P6434 Mictor adapter (see Figure 1-6 on page 1-9) allows you to connect the compression footprint to the Mictor connector pins used by the P6434 Probe. You can connect the adapter to the target system without turning off the target system. Connect the adapter according to the following steps.

NOTE. *To use this adapter do not install press-in nuts. However if board thickness is $>.093$ in, you will need to install press-in nuts before migrating to P68xx probes.*

1. Place the adapter at a perpendicular angle on top of the compression footprint.
2. Place the backing plate on the underside of the PCB.

3. Connect the backing plate by sliding the two screws into the existing screw holes from the underside of the PCB and finger-tighten the screws until snug, not to exceed 1 in-lbs.



CAUTION. *When attaching the probe head to the target system, you must use care to evenly tighten probe head screws until they are snug. First slightly tighten both screws, then snug each screw to 1 in-lbs (max). Under tightening the probe head screws can result in intermittence. Over tightening can result in damage to the elastomer holder and stripped screws.*

4. Plug the P6434 Probe into the adapter.

Screws of two different lengths are provided to attach the adapter to your PCB. The length of screw you need depends on the thickness of the PCB (0.050 in to 0.250 in).

This adapter requires use of the Compression-on-PCB to P6434 Mictor adapter land footprint. For further dimensional information refer to the Compression-on-PCB to P6434 Mictor adapter land footprint (see Figure 2-8 on page 2-29).



Reference

Reference

This section provides reference information and specifications for the P6810 General Purpose, P6860 High-Density, and P6880 High-Density Differential Probes. Topics include the following.

- Designing an interface between the probe and a target system
- Specifications

Designing an Interface Between the P6810, P6860, and P6880 Probes and a Target System

Once you have determined which probe is required, use the following information to design the appropriate connector into your target system board. The following topics are in this section:

- Signal fixturing considerations
- Signal connections (signal names and land footprints)
- Mechanical considerations
- Electrical considerations

Signal Fixturing Considerations

This section contains the following information to consider for signal fixturing:

- Clocks and qualifiers
- Merged modules and source synchronous clocking
- Demultiplexing multiplexed busses
- 2X and 4X High resolution timing modes (Internal 2X and 4X)
- Probing analog signals
- Range recognition

Clocks and Qualifiers. Every logic analyzer has some special purpose input channels. Inputs designated as clocks can cause the analyzer to store data. Qualifier channels can be logically AND'ed and OR'ed with clocks to further define when the analyzer should latch data from the system under test. Routing the appropriate signals from our design to these inputs will ensure that the analyzer can acquire data correctly.

Depending on the channel width, each TLA7Axx Series logic analyzer module will have different set of clock and qualifier channels. Table 2-1 shows the clock and qualifier channels available for each module.

Table 2-1: Logic analyzer clock and qualifier availability

| TLA7Axx Module | Clock Inputs | | | | Qualifier Inputs | | | |
|-------------------|--------------|-------|-------|-------|------------------|--------|--------|--------|
| | CLK:0 | CLK:1 | CLK:2 | CLK:3 | QUAL:0 | QUAL:1 | QUAL:2 | QUAL:3 |
| TLA7AA1 | ✓ | | | ✓ | | | | |
| TLA7AA2 | ✓ | ✓ | ✓ | ✓ | | | | |
| TLA7AA3 | ✓ | ✓ | ✓ | ✓ | ✓ | ✓ | | |
| TLA7AA4 | ✓ | ✓ | ✓ | ✓ | ✓ | ✓ | ✓ | ✓ |
| TLA7AB2 | ✓ | ✓ | ✓ | ✓ | | | | |
| TLA7AB4 | ✓ | ✓ | ✓ | ✓ | ✓ | ✓ | ✓ | ✓ |

Clock channels are dual purpose; they can be used as either clock inputs or as qualifier inputs. When not used for clocking data into the analyzer, the clock channels are free to be used as qualifiers. Additionally, all clock and qualifier channels are stored. The analyzer will always store the logic state of these channels every time it latches data.

Since clock and qualifier channels are stored in the analyzer memory there is no need to double probe these signals for timing analysis. When switching from state to timing analysis modes all of the clock and qualifier signals will be visible. This also allows you to route regular signals, those not needed for clocking, to these channels when they are not being used for their special purpose.

It is a good practice to take advantage of these channels to increase your options for when you will latch data. Routing several of your design's clocks and strobes to the analyzer clock inputs will provide you with a greater flexibility in the logic analyzer clocking setup menus.

As an example, look at a microprocessor with a master clock, data strobe, and an address strobe. Routing all three of these signals to analyzer clock inputs will enable you to latch data on the processor master clock, only when data is strobed, or only when address is strobed. Some forethought in signal routing can greatly expand the ways in which you can latch and analyze data.

A microprocessor also provides a good example of signals that can be useful as qualifiers. There are often signals that indicate data reads versus data writes (R/W), signals that show when alternate bus masters have control of the processor busses (DMA), and signals that show when various memory devices are being used (ChipSel). All of these signals are good candidates for assignment to qualifier channels.

By logically AND'ing the clock with one of these qualifiers you can program the analyzer to store only data reads or data writes. Using the DMA signal as a qualifier provides a means of filtering out alternate bus master cycles. Chip selects can limit data latching to specific memory banks, I/O ports, or peripheral devices.

Merged Module Sets and Source Synchronous Clocking. TLA7Axx analyzer modules that are 102 channels or 136 channels wide can be merged together to act as a single logic analyzer with a larger channel count. Up to five modules can be merged to provide up to a 680 channel analyzer. A unique feature of the TLA7Axx module is that it supports source synchronous clocking. Combining these two capabilities provide some additional considerations for signal routing.

Source synchronous clocking is a method which manages the skew between the system clock and the data bus by requiring the sending device to drive an actual clock or strobe signal along with the data that is very tightly coupled with it in terms of skew. The receiving device then uses this strobe to capture the data.

A variant of this scheme is being applied to large microprocessor busses, where the bus is split into smaller, more easily managed groups that each have their own dedicated strobe. Although the timing relationship between a particular clock and its associated data group is very tight, the timing between the different groups can vary greatly and changes depending on which device has control of the bus.

Many source synchronous designs use wide busses. It is not uncommon to require a set of merged logic analyzer modules to provide the channel count needed in probing larger source synchronous systems. While all of the modules in a merged set can use their clock inputs independently if needed, it must be remembered that there are a maximum of four clock inputs on a 136 channel wide module.

To see the importance of this reminder we will once again use a microprocessor system as an example. Tektronix logic analyzer processor has a 32 bit address bus and a 64 bit data bus. The data bus is split into four 16 bit subgroups that have independent source synchronous clocks. For the logic analyzer to correctly acquire data from this system it will need five clock inputs, one for the address bus and one each for the four 16 bit data bus subgroups.

To acquire both busses the analyzer would need at least 96 channels (32 address and 64 data). However, a single 102 channel card doesn't have the required five clock inputs. By merging two 102 channel modules into a set you can obtain the needed number of clock inputs. Route the address bus to one module in the set and route the data bus, along with its four source synchronous clocks, to the second module in the set.

Demultiplexing Multiplexed Busses. TLA7Axx module supports both 2X and 4X demultiplexing. Each signal on a dual or quad multiplexed bus can be demultiplexed into its own logic analyzer channel. See Tables 2-2 and 2-3 to determine which channel groups to connect to feed channels in the target system the test data.

Table 2-2: 2X Demultiplexing source-to-destination channel assignments

| Source connecting channel groups | Destination channels receiving target system test data | | | | | |
|----------------------------------|--|---------|---------|---------|---------|---------|
| | TLA7AA4 | TLA7AA3 | TLA7AA2 | TLA7AA1 | TLA7AB4 | TLA7AB2 |
| A3:7-0 | D3:7-0 | D3:7-0 | C3:7-0 | C3:7-0 | D3:7-0 | C3:7-0 |
| A2:7-0 | D2:7-0 | D2:7-0 | C2:7-0 | C2:7-0 | D2:7-0 | C2:7-0 |
| A1:7-0 | D1:7-0 | D1:7-0 | D1:7-0 | | D1:7-0 | D1:7-0 |
| A0:7-0 | D0:7-0 | D0:7-0 | D0:7-0 | | D0:7-0 | D0:7-0 |
| C3:7-0 | C1:7-0 | C1:7-0 | | | C1:7-0 | |
| C2:7-0 | C0:7-0 | C0:7-0 | | | C0:7-0 | |
| E3:7-0 | E1:7-0 | | | | E1:7-0 | |
| E2:7-0 | E0:7-0 | | | | E0:7-0 | |
| CLK:0 | QUAL:1 | QUAL:1 | | | QUAL:1 | |
| CLK:1 | QUAL:0 | QUAL:0 | | | QUAL:0 | |
| CLK:2 | QUAL:3 | | | | QUAL:3 | |
| CLK:3 | QUAL:2 | | | | QUAL:2 | |

Table 2-3: 4X Demultiplexing source-to-destination channel assignments

| Source connecting channel groups | Destination channels receiving target system test data | | | | | |
|----------------------------------|--|----------------------------|----------------------------|----------------------------|----------------------------|----------------------------|
| | TLA7AA4 | TLA7AA3 | TLA7AA2 | TLA7AA1 | TLA7AB4 | TLA7AB2 |
| C3:7-0 | C2:7-0 C1:7-0 C0:7-0 | C2:7-0 C1:7-0 C0:7-0 | A3:7-0 A2:7-0 C2:7-0 | A3:7-0 A2:7-0 C2:7-0 | C2:7-0 C1:7-0 C0:7-0 | A3:7-0 A2:7-0 C2:7-0 |
| A1:7-0 | A0:7-0 D1:7-0 D0:7-0 | A0:7-0 D1:7-0 D0:7-0 | A0:7-0 D1:7-0 D0:7-0 | | A0:7-0 D1:7-0 D0:7-0 | A0:7-0 D1:7-0 D0:7-0 |
| A3:7-0 | A2:7-0 D3:7-0 D2:7-0 | A2:7-0 D3:7-0 D2:7-0 | | | A2:7-0 D3:7-0 D2:7-0 | |
| E3:7-0 | E2:7-0 E1:7-0 E0:7-0 | | | | E2:7-0 E1:7-0 E0:7-0 | |
| CLK:3 | CLK:2 QUAL:3 QUAL:2 | | | | CLK:2 QUAL:3 QUAL:2 | |
| CLK:1 | CLK:0 QUAL:1 QUAL:0 | CLK:0 QUAL:1 QUAL:0 | | | CLK:0 QUAL:1 QUAL:0 | |

When demultiplexing data there is no need to connect the destination channels to the multiplexed bus. Data from the source channels are routed to the destination channels internal to the logic analyzer. Tables 2-2 and 2-3 show the mapping of source channels to destination channels.

Demultiplexing affects only the main memory for the destination channels. This means that the MagniVu memory is filled with data from whatever is connected to the demultiplexing destination channel probe inputs. This provides an opportunity to acquire high resolution MagniVu data on a few extra channels. Connecting the demultiplexing destination channels to other signals will allow viewing of their activity in the MagniVu memory but not the main memory.

2X and 4X High Resolution Timing Modes. 2X high resolution timing mode provides double the normal 500 MHz sample rate on one half of the channels. By trading half of the analyzers channels the remaining channels can be sampled at a 1 GHz rate with double the memory depth. 4X high resolution timing mode provides quadruple the normal 500 MHz sample rate on one fourth of the channels. By trading three-fourths of the analyzers channels the remaining channels can be sampled at a 2 GHz rate with quadruple the memory depth.

Both of the high resolution timing modes use the same demultiplexing channel routing as shown in Tables 2-2 and 2-3. By taking care to assign critical signals to the demultiplexing source channels you can obtain extra timing resolution where most needed. Since demultiplexing affects only the main memory you will still have the MagniVu data available for all of the signals that are disconnected from the main memory when you switch to the high resolution timing modes.

Probing Analog Signals. TLA7Axx module provides visibility of analog signals with iView. iView routes the actual signal seen by each channel's probe through a high bandwidth path to an analog multiplexer inside of the logic analyzer module. From the logic analyzer interface you can route any input channel to one of four output connectors on the module. By connecting the analyzer iView analog probe outputs to your oscilloscope you can see the analog characteristics of any signal probed by the logic analyzer.

Sometimes there are analog signals that would be convenient to have fixtured for easier probing. Signals such as A/D Converter inputs, D/A Converter outputs, low voltage power supplies, termination voltages, and oscillator outputs are just a few examples. Routing these signals to unused logic analyzer inputs provides a quick method of viewing their activity without ever picking up a scope probe.

Care must be taken to ensure that such signals are voltage limited and will not exceed the maximum nondestructive input voltage for the logic analyzer probes of ± 15 V_{peak}.

Range Recognition. When using range recognizers, the probe groups and probe channels must be in hardware order. Probe groups must be used from the most-significant probe group to the least-significant probe group based on the following order:

C3 C2 C1 C0 E3 E2 E1 E0 A3 A2 D3 D2 A1 A0 D1 D0 Q3 Q2 Q1 Q0 CK3
CK2 CK1 CK0

Probe channels must be from the most-significant channel to the least-significant channel based on the following order:

7 6 5 4 3 2 1 0

The above examples assumes a 136-channel LA module. The missing channels in LA modules with fewer than 136 channels are ignored. With merged modules, range recognition extends across the first three modules: the master module contains the most-significant channels.

Signal Names

See Tables 2-4 through 2-13 for the P6810, P6860, and P6880 Probes and adapters signal connections.

Table 2-4: P6810 Probe signal connections on 136 and 102 channel modules for probe #4 and probe # 3

| | | 136 channel module | | | | 102 channel module | | | |
|-------------|----------|--------------------|-------------|-------------|-------------|--------------------|-------------|-------------|-------------|
| | | Probe #4 | | | | Probe #3 | | | |
| Signal name | Podlet | Way Station | Way Station | Way Station | Way Station | Way Station | Way Station | Way Station | Way Station |
| Clk/Qual | Clk/Qual | Q3- | | Q2- | | CK0- | | Q0- | |
| Clk/Qual+ | Clk/Qual | Q3+ | | Q2+ | | CK0+ | | Q0+ | |
| Data 7- | 7 | E3:7- | E2:7- | E1:7- | E0:7- | A3:7- | A2:7- | D3:7- | D2:7- |
| Data 7+ | 7 | E3:7+ | E2:7+ | E1:7+ | E0:7+ | A3:7+ | A2:7+ | D3:7+ | D2:7+ |
| Data 6- | 6 | E3:6- | E2:6- | E1:6- | E0:6- | A3:6- | A2:6- | D3:6- | D2:6- |
| Data 6+ | 6 | E3:6+ | E2:6+ | E1:6+ | E0:6+ | A3:6+ | A2:6+ | D3:6+ | D2:6+ |
| Data 5- | 5 | E3:5- | E2:5- | E1:5- | E0:5- | A3:5- | A2:5- | D3:5- | D2:5- |
| Data 5+ | 5 | E3:5+ | E2:5+ | E1:5+ | E0:5+ | A3:5+ | A2:5+ | D3:5+ | D2:5+ |
| Data 4- | 4 | E3:4- | E2:4- | E1:4- | E0:4- | A3:4- | A2:4- | D3:4- | D2:4- |
| Data 4+ | 4 | E3:4+ | E2:4+ | E1:4+ | E0:4+ | A3:4+ | A2:4+ | D3:4+ | D2:4+ |
| Data 3- | 3 | E3:3- | E2:3- | E1:3- | E0:3- | A3:3- | A2:3- | D3:3- | D2:3- |
| Data 3+ | 3 | E3:3+ | E2:3+ | E1:3+ | E0:3+ | A3:3+ | A2:3+ | D3:3+ | D2:3+ |
| Data 2- | 2 | E3:2- | E2:2- | E1:2- | E0:2- | A3:2- | A2:2- | D3:2- | D2:2- |
| Data 2+ | 2 | E3:2+ | E2:2+ | E1:2+ | E0:2+ | A3:2+ | A2:2+ | D3:2+ | D2:2+ |
| Data 1- | 1 | E3:1- | E2:1- | E1:1- | E0:1- | A3:1- | A2:1- | D3:1- | D2:1- |
| Data 1+ | 1 | E3:1+ | E2:1+ | E1:1+ | E0:1+ | A3:1+ | A2:1+ | D3:1+ | D2:1+ |
| Data 0- | 0 | E3:0- | E2:0- | E1:0- | E0:0- | A3:0- | A2:0- | D3:0- | D2:0- |
| Data 0+ | 0 | E3:0+ | E2:0+ | E1:0+ | E0:0+ | A3:0+ | A2:0+ | D3:0+ | D2:0+ |

Refer to Table 2-2 on page 2-4 and Table 2-3 on page 2-5 for 2X and 4X demultiplexing channel assignments.

Any differential input, either the differential clock/qualifiers or the P6860 High-density Probe, or all differential data and clock/qualifiers on the P6810 General Purpose Differential Probe and P6880 High-density Differential Probe, may have their negative input pin grounded and be used as a single-ended input.

Table 2-5: Probe signal connections on 102 and 136 channel modules for probe #2 and probe #1

| | | Probe #2 | | | | Probe #1 | | | |
|-------------|-----------|-------------|-------------|-------------|-------------|-------------|-------------|-------------|-------------|
| Signal name | Podlet | Way Station | Way Station | Way Station | Way Station | Way Station | Way Station | Way Station | Way Station |
| Clk/Qual- | Clk/Qual- | CK1- | | CK2- | | CK3- | | Q1- | |
| Clk/Qual+ | Clk/Qual+ | CK1+ | | CK2+ | | CK3+ | | Q1+ | |
| Data 7- | 7 | A1:7- | A0:7- | D1:7- | D0:7- | C3:7- | C2:7- | C1:7- | C0:7- |
| Data 7+ | 7 | A1:7+ | A0:7+ | D1:7+ | D0:7+ | C3:7+ | C2:7+ | C1:7+ | C0:7+ |
| Data 6- | 6 | A1:6- | A0:6- | D1:6- | D0:6- | C3:6- | C2:6- | C1:6- | C0:6- |
| Data 6+ | 6 | A1:6+ | A0:6+ | D1:6+ | D0:6+ | C3:6+ | C2:6+ | C1:6+ | C0:6+ |
| Data 5- | 5 | A1:5- | A0:5- | D1:5- | D0:5- | C3:5- | C2:5- | C1:5- | C0:5- |
| Data 5+ | 5 | A1:5+ | A0:5+ | D1:5+ | D0:5+ | C3:5+ | C2:5+ | C1:5+ | C0:5+ |
| Data 4- | 4 | A1:4- | A0:4- | D1:4- | D0:4- | C3:4- | C2:4- | C1:4- | C0:4- |
| Data 4+ | 4 | A1:4+ | A0:4+ | D1:4+ | D0:4+ | C3:4+ | C2:4+ | C1:4+ | C0:4+ |
| Data 2+ | 2 | A1:2+ | A0:2+ | D1:2+ | D0:2+ | C3:2+ | C2:2+ | C1:2+ | C0:2+ |
| Data 3- | 3 | A1:3- | A0:3- | D1:3- | D0:3- | C3:3- | C2:3- | C1:3- | C0:3- |
| Data 3+ | 3 | A1:3+ | A0:3+ | D1:3+ | D0:3+ | C3:3+ | C2:3+ | C1:3+ | C0:3+ |
| Data 2- | 2 | A1:2- | A0:2- | D1:2- | D0:2- | C3:2- | C2:2- | C1:2- | C0:2- |
| Data 1- | 1 | A1:1- | A0:1- | D1:1- | D0:1- | C3:1- | C2:1- | C1:1- | C0:1- |
| Data 1+ | 1 | A1:1+ | A0:1+ | D1:1+ | D0:1+ | C3:1+ | C2:1+ | C1:1+ | C0:1+ |
| Data 0- | 0 | A1:0- | A0:0- | D1:0- | D0:0- | C3:0- | C2:0- | C1:0- | C0:0- |
| Data 0+ | 0 | A1:0+ | A0:0+ | D1:0+ | D0:0+ | C3:0+ | C2:0+ | C1:0+ | C0:0+ |

Refer to Table 2-2 on page 2-4 and Table 2-3 on page 2-5 for 2X and 4X demultiplexing channel assignments.

Any differential input, either the differential clock/qualifiers or the P6860 High-density Probe, or all differential data and clock/qualifiers on the P6810 General Purpose Differential Probe and P6880 High-density Differential Probe, may have their negative input pin grounded and be used as a single-ended input.

Table 2-6: P6810 Probe signal connections on 68 and 34 channel modules

| | | 68 channel module | | | | 34 channel module | | | |
|-------------|----------|-------------------|-------------|-------------|-------------|-------------------|-------------|-------------|-------------|
| | | Probe #2 | | | | Probe #1 | | | |
| Signal name | Podlet | Way Station | Way Station | Way Station | Way Station | Way Station | Way Station | Way Station | Way Station |
| Clk/Qual | Clk/Qual | CK1- | | CK2- | | CK3- | | CK0- | |
| Clk/Qual+ | Clk/Qual | CK1+ | | CK2+ | | CK3+ | | CK0+ | |
| Data 7- | 7 | A1:7- | A0:7- | D1:7- | D0:7- | C3:7- | C2:7- | A3:7- | A2:7- |
| Data 7+ | 7 | A1:7+ | A0:7+ | D1:7+ | D0:7+ | C3:7+ | C2:7+ | A3:7+ | A2:7+ |
| Data 6- | 6 | A1:6- | A0:6- | D1:6- | D0:6- | C3:6- | C2:6- | A3:6- | A2:6- |
| Data 6+ | 6 | A1:6+ | A0:6+ | D1:6+ | D0:6+ | C3:6+ | C2:6+ | A3:6+ | A2:6+ |
| Data 5- | 5 | A1:5- | A0:5- | D1:5- | D0:5- | C3:5- | C2:5- | A3:5- | A2:5- |
| Data 5+ | 5 | A1:5+ | A0:5+ | D1:5+ | D0:5+ | C3:5+ | C2:5+ | A3:5+ | A2:5+ |
| Data 4- | 4 | A1:4- | A0:4- | D1:4- | D0:4- | C3:4- | C2:4- | A3:4- | A2:4- |
| Data 4+ | 4 | A1:4+ | A0:4+ | D1:4+ | D0:4+ | C3:4+ | C2:4+ | A3:4+ | A2:4+ |
| Data 3- | 3 | A1:3- | A0:3- | D1:3- | D0:3- | C3:3- | C2:3- | A3:3- | A2:3- |
| Data 3+ | 3 | A1:3+ | A0:3+ | D1:3+ | D0:3+ | C3:3+ | C2:3+ | A3:3+ | A2:3+ |
| Data 2- | 2 | A1:2- | A0:2- | D1:2- | D0:2- | C3:2- | C2:2- | A3:2- | A2:2- |
| Data 2+ | 2 | A1:2+ | A0:2+ | D1:2+ | D0:2+ | C3:2+ | C2:2+ | A3:2+ | A2:2+ |
| Data 1- | 1 | A1:1- | A0:1- | D1:1- | D0:1- | C3:1- | C2:1- | A3:1- | A2:1- |
| Data 1+ | 1 | A1:1+ | A0:1+ | D1:1+ | D0:1+ | C3:1+ | C2:1+ | A3:1+ | A2:1+ |
| Data 0- | 0 | A1:0- | A0:0- | D1:0- | D0:0- | C3:0- | C2:0- | A3:0- | A2:0- |
| Data 0+ | 0 | A1:0+ | A0:0+ | D1:0+ | D0:0+ | C3:0+ | C2:0+ | A3:0+ | A2:0+ |

Refer to Table 2-2 on page 2-4 and Table 2-3 on page 2-5 for 2X and 4X demultiplexing channel assignments.

Any differential input, either the differential clock/qualifiers or the P6860 High-density Probe, or all differential data and clock/qualifiers on the P6810 General Purpose Differential Probe and P6880 High-density Differential Probe, may have their negative input pin grounded and be used as a single-ended input.

Table 2- 7: P6860 High-Density Probe channel mapping on 136 and 102 channel modules

| | | 136 channel module | | | | | | | |
|-------------|----------|--------------------|------------|------------|------------|------------|------------|------------|------------|
| | | 102 channel module | | | | | | | |
| | | Probe #4 | | Probe #3 | | Probe #2 | | Probe #1 | |
| Signal name | Pad name | Probe head | Probe head | Probe head | Probe head | Probe head | Probe head | Probe head | Probe head |
| Clk/Qual- | A15 | Q3- | Q2- | CK0- | Q0- | CK1- | CK2- | CK3- | Q1- |
| GND | A14 | GND | GND | GND | GND | GND | GND | GND | GND |
| Clk/Qual+ | A13 | Q3+ | Q2+ | CK0+ | Q0+ | CK1+ | CK2+ | CK3+ | Q1+ |
| Data 15 | B12 | E3:7 | E1:7 | A3:7 | D3:7 | A1:7 | D1:7 | C3:7 | C1:7 |
| GND | B11 | GND | GND | GND | GND | GND | GND | GND | GND |
| Data 14 | B10 | E3:6 | E1:6 | A3:6 | D3:6 | A1:6 | D1:6 | C3:6 | C1:6 |
| Data 13 | A12 | E3:5 | E1:5 | A3:5 | D3:5 | A1:5 | D1:5 | C3:5 | C1:5 |
| GND | A11 | GND | GND | GND | GND | GND | GND | GND | GND |
| Data 12 | A10 | E3:4 | E1:4 | A3:4 | D3:4 | A1:4 | D1:4 | C3:4 | C1:4 |
| Data 11 | B9 | E3:3 | E1:3 | A3:3 | D3:3 | A1:3 | D1:3 | C3:3 | C1:3 |
| GND | B8 | GND | GND | GND | GND | GND | GND | GND | GND |
| Data 10 | B7 | E3:2 | E1:2 | A3:2 | D3:2 | A1:2 | D1:2 | C3:2 | C1:2 |
| Data 9 | A9 | E3:1 | E1:1 | A3:1 | D3:1 | A1:1 | D1:1 | C3:1 | C1:1 |
| GND | A8 | GND | GND | GND | GND | GND | GND | GND | GND |
| Data 8 | A7 | E3:0 | E1:0 | A3:0 | D3:0 | A1:0 | D1:0 | C3:0 | C1:0 |
| Data 7 | B6 | E2:7 | E0:7 | A2:7 | D2:7 | A0:7 | D0:7 | C2:7 | C0:7 |
| GND | B5 | GND | GND | GND | GND | GND | GND | GND | GND |
| Data 6 | B4 | E2:6 | E0:6 | A2:6 | D2:6 | A0:6 | D0:6 | C2:6 | C0:6 |
| Data 5 | A6 | E2:5 | E0:5 | A2:5 | D2:5 | A0:5 | D0:5 | C2:5 | C0:5 |
| GND | A5 | GND | GND | GND | GND | GND | GND | GND | GND |
| Data 4 | A4 | E2:4 | E0:4 | A2:4 | D2:4 | A0:4 | D0:4 | C2:4 | C0:4 |
| Data 3 | B3 | E2:3 | E0:3 | A2:3 | D2:3 | A0:3 | D0:3 | C2:3 | C0:3 |
| GND | B2 | GND | GND | GND | GND | GND | GND | GND | GND |
| Data 2 | B1 | E2:2 | E0:2 | A2:2 | D2:2 | A0:2 | D0:2 | C2:2 | C0:2 |
| Data 1 | A3 | E2:1 | E0:1 | A2:1 | D2:1 | A0:1 | D0:1 | C2:1 | C0:1 |
| GND | A2 | GND | GND | GND | GND | GND | GND | GND | GND |
| Data 0 | A1 | E2:0 | E0:0 | A2:0 | D2:0 | A0:0 | D0:0 | C2:0 | C0:0 |

Refer to Table 2-2 on page 2-4 and Table 2-3 on page 2-5 for 2X and 4X demultiplexing channel assignments.

Any differential input, either the differential clock/qualifiers or the P6860 High-density Probe, or all differential data and clock/qualifiers on the P6810 General Purpose Differential Probe and P6880 High-density Differential Probe, may have their negative input pin grounded and be used as a single-ended input.

Table 2-8: P6860 High-Density Probe channel mapping on 68 and 34 channel modules

| Signal name | | 68 channel module | | | |
|-------------|-----|-------------------|------------|-------------------|------------|
| | | Probe #2 | | 34 channel module | |
| | | Probe head | Probe head | Probe head | Probe head |
| Clk/Qual- | A15 | CK1- | CK2- | CK3- | CK0- |
| GND | A14 | GND | GND | GND | GND |
| Clk/Qual+ | A13 | CK1 | CK2 | CK3 | CK0 |
| Data 15 | B12 | A1:7 | D1:7 | C3:7 | A3:7 |
| GND | B11 | GND | GND | GND | GND |
| Data 14 | B10 | A1:6 | D1:6 | C3:6 | A3:6 |
| Data 13 | A12 | A1:5 | D1:5 | C3:5 | A3:5 |
| GND | A11 | GND | GND | GND | GND |
| Data 12 | A10 | A1:4 | D1:4 | C3:4 | A3:4 |
| Data 11 | B9 | A1:3 | D1:3 | C3:3 | A3:3 |
| GND | B8 | GND | GND | GND | GND |
| Data 10 | B7 | A1:2 | D1:2 | C3:2 | A3:2 |
| Data 9 | A9 | A1:1 | D1:1 | C3:1 | A3:1 |
| GND | A8 | GND | GND | GND | GND |
| Data 8 | A7 | A1:0 | D1:0 | C3:0 | A3:0 |
| Data 7 | B6 | A0:7 | D0:7 | C2:7 | A2:7 |
| GND | B5 | GND | GND | GND | GND |
| Data 6 | B4 | A0:6 | D0:6 | C2:6 | A2:6 |
| Data 5 | A6 | A0:5 | D0:5 | C2:5 | A2:5 |
| GND | A5 | GND | GND | GND | GND |
| Data 4 | A4 | A0:4 | D0:4 | C2:4 | A2:4 |
| Data 3 | B3 | A0:3 | D0:3 | C2:3 | A2:3 |
| GND | B2 | GND | GND | GND | GND |
| Data 2 | B1 | A0:2 | D0:2 | C2:2 | A2:2 |
| Data 1 | A3 | A0:1 | D0:1 | C2:1 | A2:1 |
| GND | A2 | GND | GND | GND | GND |
| Data 0 | A1 | A0:0 | D0:0 | C2:0 | A2:0 |

Refer to Table 2-2 on page 2-4 and Table 2-3 on page 2-5 for 2X and 4X demultiplexing channel assignments.

Any differential input, either the differential clock/qualifiers or the P6860 High-density Probe, or all differential data and clock/qualifiers on the P6810 General Purpose Differential Probe and P6880 High-density Differential Probe, may have their negative input pin grounded and be used as a single-ended input.

Table 2-9: P6880 High-Density Differential Probe channel mapping on 136 and 102 channel modules for probe #4 and probe #3

| | | 136 channel module | | | | 102 channel module | | | |
|-------------|----------|--------------------|------------|------------|------------|--------------------|------------|------------|------------|
| | | Probe #4 | | | | Probe #3 | | | |
| Signal name | Pad name | Probe head | Probe head | Probe head | Probe head | Probe head | Probe head | Probe head | Probe head |
| Clk/Qual- | A15 | Q3- | | Q2- | | CK0- | | Q0- | |
| GND | A14 | GND | GND | GND | GND | GND | GND | GND | GND |
| Clk/Qual+ | A13 | Q3+ | | Q2+ | | CK0+ | | Q0+ | |
| Data 7+ | B12 | E3:7+ | E2:7+ | E1:7+ | E0:7+ | A3:7+ | A2:7+ | D3:7+ | D2:7+ |
| GND | B11 | GND | GND | GND | GND | GND | GND | GND | GND |
| Data 7- | B10 | E3:7- | E2:7- | E1:7- | E0:7- | A3:7- | A2:7- | D3:7- | D2:7- |
| Data 6- | A12 | E3:6- | E2:6- | E1:6- | E0:6- | A3:6- | A2:6- | D3:6- | D2:6- |
| GND | A11 | GND | GND | GND | GND | GND | GND | GND | GND |
| Data 6+ | A10 | E3:6+ | E2:6+ | E1:6+ | E0:6+ | A3:6+ | A2:6+ | D3:6+ | D2:6+ |
| Data 5+ | B9 | E3:5+ | E2:5+ | E1:5+ | E0:5+ | A3:5+ | A2:5+ | D3:5+ | D2:5+ |
| GND | B8 | GND | GND | GND | GND | GND | GND | GND | GND |
| Data 5- | B7 | E3:5- | E2:5- | E1:5- | E0:5- | A3:5- | A2:5- | D3:5- | D2:5- |
| Data 4- | A9 | E3:4- | E2:4- | E1:4- | E0:4- | A3:4- | A2:4- | D3:4- | D2:4- |
| GND | A8 | GND | GND | GND | GND | GND | GND | GND | GND |
| Data 4+ | A7 | E3:4+ | E2:4+ | E1:4+ | E0:4+ | A3:4+ | A2:4+ | D3:4+ | D2:4+ |
| Data 3+ | B6 | E3:3+ | E2:3+ | E1:3+ | E0:3+ | A3:3+ | A2:3+ | D3:3+ | D2:3+ |
| GND | B5 | GND | GND | GND | GND | GND | GND | GND | GND |
| Data 3- | B4 | E3:3- | E2:3- | E1:3- | E0:3- | A3:3- | A2:3- | D3:3- | D2:3- |
| Data 2- | A6 | E3:2- | E2:2- | E1:2- | E0:2- | A3:2- | A2:2- | D3:2- | D2:2- |
| GND | A5 | GND | GND | GND | GND | GND | GND | GND | GND |
| Data 2+ | A4 | E3:2+ | E2:2+ | E1:2+ | E0:2+ | A3:2+ | A2:2+ | D3:2+ | D2:2+ |
| Data 1+ | B3 | E3:1+ | E2:1+ | E1:1+ | E0:1+ | A3:1+ | A2:1+ | D3:1+ | D2:1+ |
| GND | B2 | GND | GND | GND | GND | GND | GND | GND | GND |
| Data 1- | B1 | E3:1- | E2:1- | E1:1- | E0:1- | A3:1- | A2:1- | D3:1- | D2:1- |
| Data 0- | A3 | E3:0- | E2:0- | E1:0- | E0:0- | A3:0- | A2:0- | D3:0- | D2:0- |
| GND | A2 | GND | GND | GND | GND | GND | GND | GND | GND |
| Data 0+ | A1 | E3:0+ | E2:0+ | E1:0+ | E0:0+ | A3:0+ | A2:0+ | D3:0+ | D2:0+ |

Refer to Table 2-2 on page 2-4 and Table 2-3 on page 2-5 for 2X and 4X demultiplexing channel assignments.

Any differential input, either the differential clock/qualifiers or the P6860 High-density Probe, or all differential data and clock/qualifiers on the P6810 General Purpose Differential Probe and P6880 High-density Differential Probe, may have their negative input pin grounded and be used as a single-ended input.

Table 2- 10: P6880 High-Density Differential Probe channel mapping on 136 and 102 channel modules for probe #2 and probe #1

| Signal name | Pad name | Probe #2 | | | | Probe #1 | | | |
|-------------|----------|------------|------------|------------|------------|------------|------------|------------|------------|
| | | Probe head | Probe head | Probe head | Probe head | Probe head | Probe head | Probe head | Probe head |
| Clk/Qual- | A15 | CK1- | | CK2- | | CK3- | | Q1- | |
| GND | A14 | GND | GND | GND | GND | GND | GND | GND | GND |
| Clk/Qual+ | A13 | CK1- | | CK2- | | CK3+ | | Q1+ | |
| Data 7+ | B12 | A1:7+ | A0:7+ | D1:7+ | D0:7+ | C3:7+ | C2:7+ | C1:7+ | C0:7+ |
| GND | B11 | GND | GND | GND | GND | GND | GND | GND | GND |
| Data 7- | B10 | A1:7- | A0:7- | D1:7- | D0:7- | C3:7- | C2:7- | C1:7- | C0:7- |
| Data 6- | A12 | A1:6- | A0:6- | D1:6- | D0:6- | C3:6- | C2:6- | C2:6- | C0:6- |
| GND | A11 | GND | GND | GND | GND | GND | GND | GND | GND |
| Data 6+ | A10 | A1:6+ | A0:6+ | D1:6+ | D0:6+ | C3:6+ | C2:6+ | C1:6+ | C0:6+ |
| Data 5+ | B9 | A1:5+ | A0:5+ | D1:5+ | D0:5+ | C3:5+ | C2:5+ | C1:5+ | C0:5+ |
| GND | B8 | GND | GND | GND | GND | GND | GND | GND | GND |
| Data 5- | B7 | A1:5- | A0:5- | D1:5- | D0:5- | C3:5- | C2:5- | C1:5- | C0:5- |
| Data 4- | A9 | A1:4- | A0:4- | D1:4- | D0:4- | C3:4- | C2:4- | C1:4- | C0:4- |
| GND | A8 | GND | GND | GND | GND | GND | GND | GND | GND |
| Data 4+ | A7 | A1:4+ | A0:4+ | D1:4+ | D0:4+ | C3:4+ | C2:4+ | C1:4+ | C0:4+ |
| Data 3+ | B6 | A1:3+ | A0:3+ | D1:3+ | D0:3+ | C3:3+ | C2:3+ | C1:3+ | C0:3+ |
| GND | B5 | GND | GND | GND | GND | GND | GND | GND | GND |
| Data 3- | B4 | A1:3- | A0:3- | D1:3- | D0:3- | C3:3- | C2:3- | C1:3- | C0:3- |
| Data 2- | A6 | A1:2- | A0:2- | D1:2- | D0:2- | C3:2- | C2:2- | C1:2- | C0:2- |
| GND | A5 | GND | GND | GND | GND | GND | GND | GND | GND |
| Data 2+ | A4 | A1:2+ | A0:2+ | D1:2+ | D0:2+ | C3:2+ | C2:2+ | C1:2+ | C0:2+ |
| Data 1+ | B3 | A1:1+ | A0:1+ | D1:1+ | D0:1+ | C3:1+ | C2:1+ | C1:1+ | C0:1+ |
| GND | B2 | GND | GND | GND | GND | GND | GND | GND | GND |
| Data 1- | B1 | A1:1- | A0:1- | D1:1- | D0:1- | C3:1- | C2:1- | C1:1- | C0:1- |
| Data 0- | A3 | A1:0- | A0:0- | D1:0- | D0:0- | C3:0- | C2:0- | C1:0- | C0:0- |
| GND | A2 | GND | GND | GND | GND | GND | GND | GND | GND |
| Data 0+ | A1 | A1:0+ | A0:0+ | D1:0+ | D0:0+ | C3:0+ | C2:0+ | C1:0+ | C0:0+ |

Refer to Table 2-2 on page 2-4 and Table 2-3 on page 2-5 for 2X and 4X demultiplexing channel assignments.

Any differential input, either the differential clock/qualifiers or the P6860 High-density Probe, or all differential data and clock/qualifiers on the P6810 General Purpose Differential Probe and P6880 High-density Differential Probe, may have their negative input pin grounded and be used as a single-ended input.

Table 2- 11: P6880 High-Density Differential Probe channel mapping on 68 and 34 channel modules

| | | 68 channel module | | | | 34 channel module | | | |
|-------------|----------|-------------------|------------|------------|------------|-------------------|------------|------------|------------|
| | | Probe #2 | | | | Probe #1 | | | |
| Signal name | Pad name | Probe head | Probe head | Probe head | Probe head | Probe head | Probe head | Probe head | Probe head |
| Clk/Qual- | A15 | CK1- | | CK2- | | CK3- | | CK0- | |
| GND | A14 | GND | GND | GND | GND | GND | GND | GND | GND |
| Clk/Qual+ | A13 | CK1- | | CK2- | | CK3+ | | CK0+ | |
| Data 7+ | B12 | A1:7+ | A0:7+ | D1:7+ | D0:7+ | C3:7+ | C2:7+ | A3:7+ | A2:7+ |
| GND | B11 | GND | GND | GND | GND | GND | GND | GND | GND |
| Data 7- | B10 | A1:7- | A0:7- | D1:7- | D0:7- | C3:7- | C2:7- | A3:7- | A2:7- |
| Data 6- | A12 | A1:6- | A0:6- | D1:6- | D0:6- | C3:6- | C2:6- | A3:6- | A2:6- |
| GND | A11 | GND | GND | GND | GND | GND | GND | GND | GND |
| Data 6+ | A10 | A1:6+ | A0:6+ | D1:6+ | D0:6+ | C3:6+ | C2:6+ | A3:6+ | A2:6+ |
| Data 5+ | B9 | A1:5+ | A0:5+ | D1:5+ | D0:5+ | C3:5+ | C2:5+ | A3:5+ | A2:5+ |
| GND | B8 | GND | GND | GND | GND | GND | GND | GND | GND |
| Data 5- | B7 | A1:5- | A0:5- | D1:5- | D0:5- | C3:5- | C2:5- | A3:5- | A2:5- |
| Data 4- | A9 | A1:4- | A0:4- | D1:4- | D0:4- | C3:4- | C2:4- | A3:4- | A2:4- |
| GND | A8 | GND | GND | GND | GND | GND | GND | GND | GND |
| Data 4+ | A7 | A1:4+ | A0:4+ | D1:4+ | D0:4+ | C3:4+ | C2:4+ | A3:4+ | A2:4+ |
| Data 3+ | B6 | A1:3+ | A0:3+ | D1:3+ | D0:3+ | C3:3+ | C2:3+ | A3:3+ | A2:3+ |
| GND | B5 | GND | GND | GND | GND | GND | GND | GND | GND |
| Data 3- | B4 | A1:3- | A0:3- | D1:3- | D0:3- | C3:3- | C2:3- | A3:3- | A2:3- |
| Data 2- | A6 | A1:2- | A0:2- | D1:2- | D0:2- | C3:2- | C2:2- | A3:2- | A2:2- |
| GND | A5 | GND | GND | GND | GND | GND | GND | GND | GND |
| Data 2+ | A4 | A1:2+ | A0:2+ | D1:2+ | D0:2+ | C3:2+ | C2:2+ | A3:2+ | A2:2+ |
| Data 1+ | B3 | A1:1+ | A0:1+ | D1:1+ | D0:1+ | C3:1+ | C2:1+ | A3:1+ | A2:1+ |
| GND | B2 | GND | GND | GND | GND | GND | GND | GND | GND |
| Data 1- | B1 | A1:1- | A0:1- | D1:1- | D0:1- | C3:1- | C2:1- | A3:1- | A2:1- |
| Data 0- | A3 | A1:0- | A0:0- | D1:0- | D0:0- | C3:0- | C2:0- | A3:0- | A2:0- |
| GND | A2 | GND | GND | GND | GND | GND | GND | GND | GND |
| Data 0+ | A1 | A1:0+ | A0:0+ | D1:0+ | D0:0+ | C3:0+ | C2:0+ | A3:0+ | A2:0+ |

Refer to Table 2-2 on page 2-4 and Table 2-3 on page 2-5 for 2X and 4X demultiplexing channel assignments.

Any differential input, either the differential clock/qualifiers or the P6860 High-density Probe, or all differential data and clock/qualifiers on the P6810 General Purpose Differential Probe and P6880 High-density Differential Probe, may have their negative input pin grounded and be used as a single-ended input.

Table 2- 12: Recommended Compression-on-PCB to P6434 Mictor adapter and Mictor-on-PCB to Compression adapter channel mapping for 136 and 102 channel modules

| | | | 136 channel module | | | |
|--------------|----------|-------------------|-------------------------|-------------------------|-------------------------|-------------------------|
| | | | 102 channel module | | | |
| Signal name | Pad name | Mictor pin number | Adapter #4/ probe #4 | Adapter #3/ probe #3 | Adapter #2/ probe #2 | Adapter #1/ probe #1 |
| J1 Clk/Qual- | A15 | NC | NC | NC | NC | NC |
| GND | A14 | GND | GND | GND | GND | GND |
| J1 Clk/Qual+ | A13 | 5 | Q3 | Q0 | CK0 | CK3 |
| J1 Data 15 | B12 | 7 | E3:7 | D3:7 | A3:7 | C3:7 |
| GND | B11 | GND | GND | GND | GND | GND |
| J1 Data 14 | B10 | 9 | E3:6 | D3:6 | A3:6 | C3:6 |
| J1 Data 13 | A12 | 11 | E3:5 | D3:5 | A3:5 | C3:5 |
| GND | A11 | GND | GND | GND | GND | GND |
| J1 Data 12 | A10 | 13 | E3:4 | D3:4 | A3:4 | C3:4 |
| J1 Data 11 | B9 | 15 | E3:3 | D3:3 | A3:3 | C3:3 |
| GND | B8 | GND | GND | GND | GND | GND |
| J1 Data 10 | B7 | 17 | E3:2 | D3:2 | A3:2 | C3:2 |
| J1 Data 9 | A9 | 19 | E3:1 | D3:1 | A3:1 | C3:1 |
| GND | A8 | GND | GND | GND | GND | GND |
| J1 Data 8 | A7 | 21 | E3:0 | D3:0 | A3:0 | C3:0 |
| J1 Data 7 | B6 | 23 | E2:7 | D2:7 | A2:7 | C2:7 |
| GND | B5 | GND | GND | GND | GND | GND |
| J1 Data 6 | B4 | 25 | E2:6 | D2:6 | A2:6 | C2:6 |
| J1 Data 5 | A6 | 27 | E2:5 | D2:5 | A2:5 | C2:5 |
| GND | A5 | GND | GND | GND | GND | GND |
| J1 Data 4 | A4 | 29 | E2:4 | D2:4 | A2:4 | C2:4 |
| J1 Data 3 | B3 | 31 | E2:3 | D2:3 | A2:3 | C2:3 |
| GND | B2 | GND | GND | GND | GND | GND |
| J1 Data 2 | B1 | 33 | E2:2 | D2:2 | A2:2 | C2:2 |
| J1 Data 1 | A3 | 35 | E2:1 | D2:1 | A2:1 | C2:1 |
| GND | A2 | GND | GND | GND | GND | GND |
| J1 Data 0 | A1 | 37 | E2:0 | D2:0 | A2:0 | C2:0 |

Refer to Table 2-2 on page 2-4 and Table 2-3 on page 2-5 for 2X and 4X demultiplexing channel assignments.

Any differential input, either the differential clock/qualifiers or the P6860 High-density Probe, or all differential data and clock/qualifiers on the P6810 General Purpose Differential Probe and P6880 High-density Differential Probe, may have their negative input pin grounded and be used as a single-ended input.

Table 2-12: Recommended Compression-on-PCB to P6434 Mictor adapter and Mictor-on-PCB to Compression adapter channel mapping for 136 and 102 channel modules (Cont.)

| | | | 136 channel module | | | |
|--------------|----------|-------------------|-------------------------|-------------------------|-------------------------|-------------------------|
| | | | 102 channel module | | | |
| Signal name | Pad name | Mictor pin number | Adapter #4/ probe #4 | Adapter #3/ probe #3 | Adapter #2/ probe #2 | Adapter #1/ probe #1 |
| J2 Clk/Qual- | A15 | NC | NC | NC | NC | NC |
| GND | A14 | GND | GND | GND | GND | GND |
| J2 Clk/Qual+ | A13 | 6 | Q2 | CK2 | CK1 | Q1 |
| J2 Data 15 | B12 | 8 | E1:7 | D1:7 | A1:7 | C1:7 |
| GND | B11 | GND | GND | GND | GND | GND |
| J2 Data 14 | B10 | 10 | E1:6 | D1:6 | A1:6 | C1:6 |
| J2 Data 13 | A12 | 12 | E1:5 | D1:5 | A1:5 | C1:5 |
| GND | A11 | GND | GND | GND | GND | GND |
| J2 Data 12 | A10 | 14 | E1:4 | D1:4 | A1:4 | C1:4 |
| J2 Data 11 | B9 | 16 | E1:3 | D1:3 | A1:3 | C1:3 |
| GND | B8 | GND | GND | GND | GND | GND |
| J2 Data 10 | B7 | 18 | E1:2 | D1:2 | A1:2 | C1:2 |
| J2 Data 9 | A9 | 20 | E1:1 | D1:1 | A1:1 | C1:1 |
| GND | A8 | GND | GND | GND | GND | GND |
| J2 Data 8 | A7 | 22 | E1:0 | D1:0 | A1:0 | C1:0 |
| J2 Data 7 | B6 | 24 | E0:7 | D0:7 | A0:7 | C0:7 |
| GND | B5 | GND | GND | GND | GND | GND |
| J2 Data 6 | B4 | 26 | E0:6 | D0:6 | A0:6 | C0:6 |
| J2 Data 5 | A6 | 28 | E0:5 | D0:5 | A0:5 | C0:5 |
| GND | A5 | GND | GND | GND | GND | GND |
| J2 Data 4 | A4 | 30 | E0:4 | D0:4 | A0:4 | C0:4 |
| J2 Data 3 | B3 | 32 | E0:3 | D0:3 | A0:3 | C0:3 |
| GND | B2 | GND | GND | GND | GND | GND |
| J2 Data 2 | B1 | 34 | E0:2 | D0:2 | A0:2 | C0:2 |
| J2 Data 1 | A3 | 36 | E0:1 | D0:1 | A0:1 | C0:1 |
| GND | A2 | GND | GND | GND | GND | GND |
| J2 Data 0 | A1 | 38 | E0:0 | D0:0 | A0:0 | C0:0 |

Refer to Table 2-2 on page 2-4 and Table 2-3 on page 2-5 for 2X and 4X demultiplexing channel assignments.

Any differential input, either the differential clock/qualifiers or the P6860 High-density Probe, or all differential data and clock/qualifiers on the P6810 General Purpose Differential Probe and P6880 High-density Differential Probe, may have their negative input pin grounded and be used as a single-ended input.

Table 2- 13: Recommended Compression-on-PCB to P6434 Mictor adapter and Mictor-on-PCB to Compression adapter channel mapping for 68 channel module

| Signal name | Pad name | Mictor pin number | Adapter #1/probe #1 | Adapter #2/probe #1 |
|--------------|----------|-------------------|---------------------|---------------------|
| J1 Clk/Qual- | A15 | NC | NC | NC |
| GND | A14 | GND | GND | GND |
| J1 Clk/Qual+ | A13 | 5 | CK0 | CK3 |
| J1 Data 15 | B12 | 7 | A3:7 | C3:7 |
| GND | B11 | GND | GND | GND |
| J1 Data 14 | B10 | 9 | A3:6 | C3:6 |
| J1 Data 13 | A12 | 11 | A3:5 | C3:5 |
| GND | A11 | GND | GND | GND |
| J1 Data 12 | A10 | 13 | A3:4 | C3:4 |
| J1 Data 11 | B9 | 15 | A3:3 | C3:3 |
| GND | B8 | GND | GND | GND |
| J1 Data 10 | B7 | 17 | A3:2 | C3:2 |
| J1 Data 9 | A9 | 19 | A3:1 | C3:1 |
| GND | A8 | GND | GND | GND |
| J1 Data 8 | A7 | 21 | A3:0 | C3:0 |
| J1 Data 7 | B6 | 23 | A2:7 | C2:7 |
| GND | B5 | GND | GND | GND |
| J1 Data 6 | B4 | 25 | A2:6 | C2:6 |
| J1 Data 5 | A6 | 27 | A2:5 | C2:5 |
| GND | A5 | GND | GND | GND |
| J1 Data 4 | A4 | 29 | A2:4 | C2:4 |
| J1 Data 3 | B3 | 31 | A2:3 | C2:3 |
| GND | B2 | GND | GND | GND |
| J1 Data 2 | B1 | 33 | A2:2 | C2:2 |
| J1 Data 1 | A3 | 35 | A2:1 | C2:1 |
| GND | A2 | GND | GND | GND |
| J1 Data 0 | A1 | 37 | A2:0 | C2:0 |

1/2 channel mode may use Adapter #1 connection signals as source.

Table 2-13: Recommended Compression-on-PCB to P6434 Mictor adapter and Mictor-on-PCB to Compression adapter channel mapping for 68 channel modules (Cont.)

| Signal name | Pad name | Mictor pin number | Adapter #1/probe #2 | Adapter #2/probe #2 |
|--------------|----------|-------------------|---------------------|---------------------|
| J2 Clk/Qual+ | A15 | NC | NC | NC |
| GND | A14 | GND | GND | GND |
| J2 Clk/Qual+ | A13 | 6 | CK1 | CK2 |
| J2 Data 15 | B12 | 8 | A1:7D1:7 | D1:7 |
| GND | B11 | GND | GND | GND |
| J2 Data 14 | B10 | 10 | A1:6 | D1:6 |
| J2 Data 13 | A12 | 12 | A1:55 | D1:5 |
| GND | A11 | GND | GND | GND |
| J2 Data 12 | A10 | 14 | A1:4 | D1:4 |
| J2 Data 11 | B9 | 16 | A1:3 | D1:3 |
| GND | B8 | GND | GND | GND |
| J2 Data 10 | B7 | 18 | A1:2 | D1:2 |
| J2 Data 9 | A9 | 20 | A1:1 | D1:1 |
| GND | A8 | GND | GND | GND |
| J2 Data 8 | A7 | 22 | A1:0 | D1:0 |
| J2 Data 7 | B6 | 24 | A0:7 | D0:7 |
| GND | B5 | GND | GND | GND |
| J2 Data 6 | B4 | 26 | A0:6 | D0:6 |
| J2 Data 5 | A6 | 28 | A0:5 | D0:5 |
| GND | A5 | GND | GND | GND |
| J2 Data 4 | A4 | 30 | A0:4 | D0:4 |
| J2 Data 3 | B3 | 32 | A0:3 | D0:3 |
| GND | B2 | GND | GND | GND |
| J2 Data 2 | B1 | 34 | A0:2 | D0:2 |
| J2 Data 1 | A3 | 36 | A0:1 | D0:1 |
| GND | A2 | GND | GND | GND |
| J2 Data 0 | A1 | 38 | A0:0 | D0:0 |

Refer to Table 2-2 on page 2-4 and Table 2-3 on page 2-5 for 2X and 4X demultiplexing channel assignments.

Any differential input, either the differential clock/qualifiers or the P6860 High-density Probe, or all differential data and clock/qualifiers on the P6810 General Purpose Differential Probe and P6880 High-density Differential Probe, may have their negative input pin grounded and be used as a single-ended input.

Table 2- 14: Recommended Compression-on-PCB to P6434 Mictor adapter and Mictor-on-PCB to Compression adapter channel mapping for 34 channel module

| Signal name | Pad name | Mictor pin number | Adapter #1/probe head #1 |
|--------------|----------|-------------------|--------------------------|
| J1 Clk/Qual- | A15 | NC | NC |
| GND | A14 | GND | GND |
| J1 Clk/Qual+ | A13 | 5 | CK3 |
| J1 Data 15 | B12 | 7 | C3:7 |
| GND | B11 | GND | GND |
| J1 Data 14 | B10 | 9 | C3:6 |
| J1 Data 13 | A12 | 11 | C3:5 |
| GND | A11 | GND | GND |
| J1 Data 12 | A10 | 13 | C3:4 |
| J1 Data 11 | B9 | 15 | C3:3 |
| GND | B8 | GND | GND |
| J1 Data 10 | B7 | 17 | C3:2 |
| J1 Data 9 | A9 | 19 | C3:1 |
| GND | A8 | GND | GND |
| J1 Data 8 | A7 | 21 | C3:0 |
| J1 Data 7 | B6 | 23 | C2:7 |
| GND | B5 | GND | GND |
| J1 Data 6 | B4 | 25 | C2:6 |
| J1 Data 5 | A6 | 27 | C2:5 |
| GND | A5 | GND | GND |
| J1 Data 4 | A4 | 29 | C2:4 |
| J1 Data 3 | B3 | 31 | C2:3 |
| GND | B2 | GND | GND |
| J1 Data 2 | B1 | 33 | C2:2 |
| J1 Data 1 | A3 | 35 | C2:1 |
| GND | A2 | GND | GND |
| J1 Data 0 | A1 | 37 | C2:0 |

Refer to Table 2-2 on page 2-4 and Table 2-3 on page 2-5 for 2X and 4X demultiplexing channel assignments.

Any differential input, either the differential clock/qualifiers or the P6860 High-density Probe, or all differential data and clock/qualifiers on the P6810 General Purpose Differential Probe and P6880 High-density Differential Probe, may have their negative input pin grounded and be used as a single-ended input.

Table 2- 14: Recommended Compression-on-PCB to P6434 Mictor adapter and Mictor-on-PCB to Compression adapter channel mapping for 34 channel modules (Cont.)

| Signal name | Pad name | Mictor pin number | Adapter #1/probe head #2 |
|--------------|----------|-------------------|--------------------------|
| J2 Clk/Qual+ | A15 | NC | NC |
| GND | A14 | GND | GND |
| J2 Clk/Qual+ | A13 | 6 | CK0 |
| J2 Data 15 | B12 | 8 | A3:7 |
| GND | B11 | GND | GND |
| J2 Data 14 | B10 | 10 | A3:6 |
| J2 Data 13 | A12 | 12 | A3:5 |
| GND | A11 | GND | GND |
| J2 Data 12 | A10 | 14 | A3:4 |
| J2 Data 11 | B9 | 16 | A3:3 |
| GND | B8 | GND | GND |
| J2 Data 10 | B7 | 18 | A3:2 |
| J2 Data 9 | A9 | 20 | A3:1 |
| GND | A8 | GND | GND |
| J2 Data 8 | A7 | 22 | A3:0 |
| J2 Data 7 | B6 | 24 | A2:7 |
| GND | B5 | GND | GND |
| J2 Data 6 | B4 | 26 | A2:6 |
| J2 Data 5 | A6 | 28 | A2:5 |
| GND | A5 | GND | GND |
| J2 Data 4 | A4 | 30 | A2:4 |
| J2 Data 3 | B3 | 32 | A2:3 |
| GND | B2 | GND | GND |
| J2 Data 2 | B1 | 34 | A2:2 |
| J2 Data 1 | A3 | 36 | A2:1 |
| GND | A2 | GND | GND |
| J2 Data 0 | A1 | 38 | A2:0 |

Refer to Table 2-2 on page 2-4 and Table 2-3 on page 2-5 for 2X and 4X demultiplexing channel assignments.

Any differential input, either the differential clock/qualifiers or the P6860 High-density Probe, or all differential data and clock/qualifiers on the P6810 General Purpose Differential Probe and P6880 High-density Differential Probe, may have their negative input pin grounded and be used as a single-ended input.

Special Considerations for the Adapters. The following are issues to consider when you use either the Compression-on-PCB to P6434 Mictor adapter or the Mictor-on-PCB to P6860 Compression adapters.

- Use of the Compression-on-PCB to P6434 Mictor and Mictor-on-PCB to P6860 Compression adapters on existing 68 and 34 channel embedded configurations and supports may require exchanging the P6860 Probe heads or P6434 module connector ends to accommodate all older Tektronix logic analyzer signal connection alternatives. For additional information on P6434 and P68xx probe-to-module orientation refer to the following:
 - *P6810 General Purpose Logic Analyzer Probe Label Instructions*
 - *P6860 High Density Logic Analyzer Probe Label Instructions*
 - *P6880 High Density Differential Logic Analyzer Probe Label Instructions*
 - *P6434 Probe Label Instructions*
- On the Compression-on-PCB to P6434 Mictor adapter, the negative side of the differential clock/quals are left floating (N/C) to allow a differential clock signal to be connected to the compression footprint and still be probed by a P6434. However, the P6434 will only see the CLK+ side of the differential line. This also allows the P6860 Probes to be connected in the future and provide true differential clock/qual support.
- On the Mictor-on-PCB to P6860 Compression adapter, the negative side of the differential clock/qual inputs on the compression connection side are internally grounded to support viewing the single-ended clock/qual inputs supported by the P6434 Probe and older Tektronix logic analyzers.

Land Footprints

The following section shows the land footprints for the P6810, P6860, and P6880 Probes. These figures contain the signal to land pattern assignments.

P6810 Probe Land Footprint. See Figure 2-1 for the P6810 General Purpose Probe land footprint. Pin spacing allows for spacing tolerance between 8-channel podlet holder and clock/qual podlet configurations. Negative inputs of differential signals may be grounded to support single-ended signal inputs.

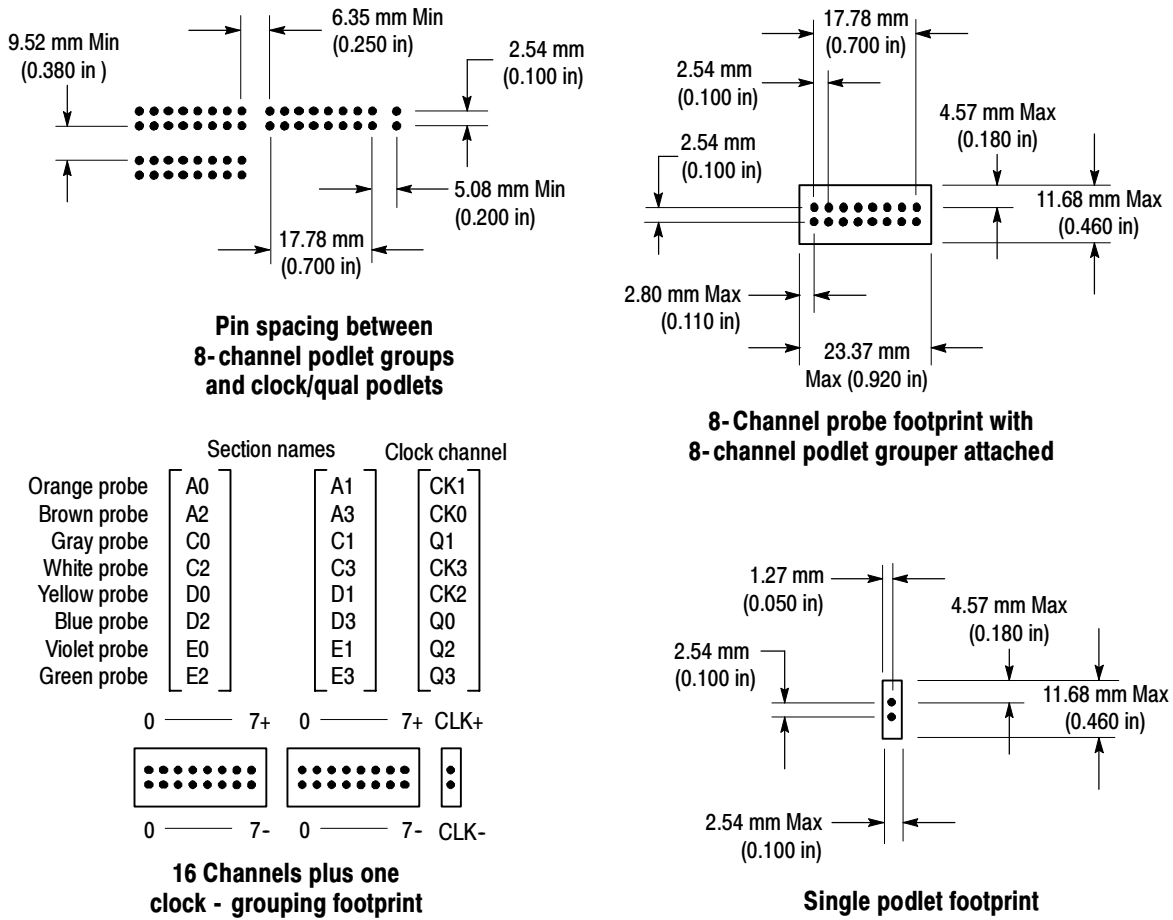

Figure 2- 1: P6810 General-Purpose probe land footprint

P6860 Probe Land Footprint. See Figure 2-2 for the land footprint for the P6860 High-Density Probe. See Figure 2-3 for an example of the High-Density Probe land footprint in a typical pass-through signal path layout configuration. This type of configuration optimizes minimal probe loading. Figure 2-4 contains example layouts of the High-Density Compression and Mictor land footprints.

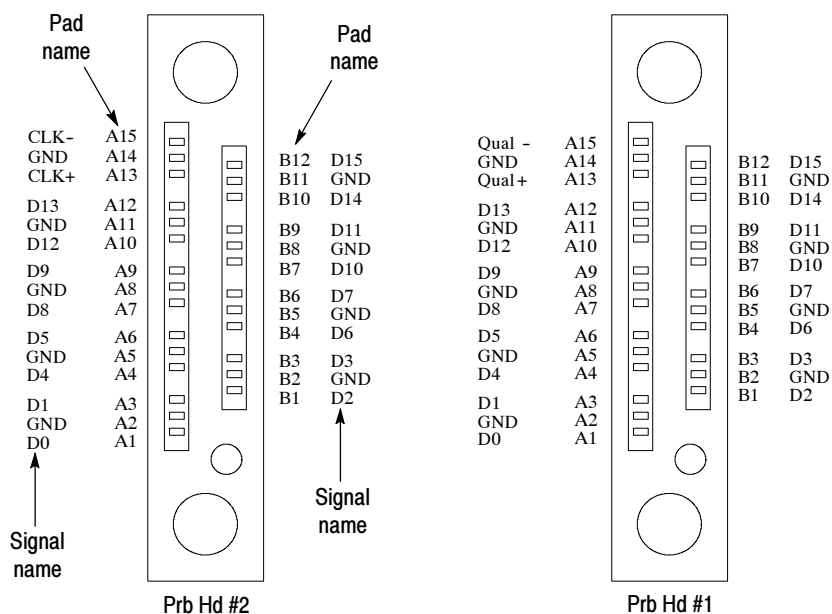

Figure 2-2: P6860 High-Density probe land footprint

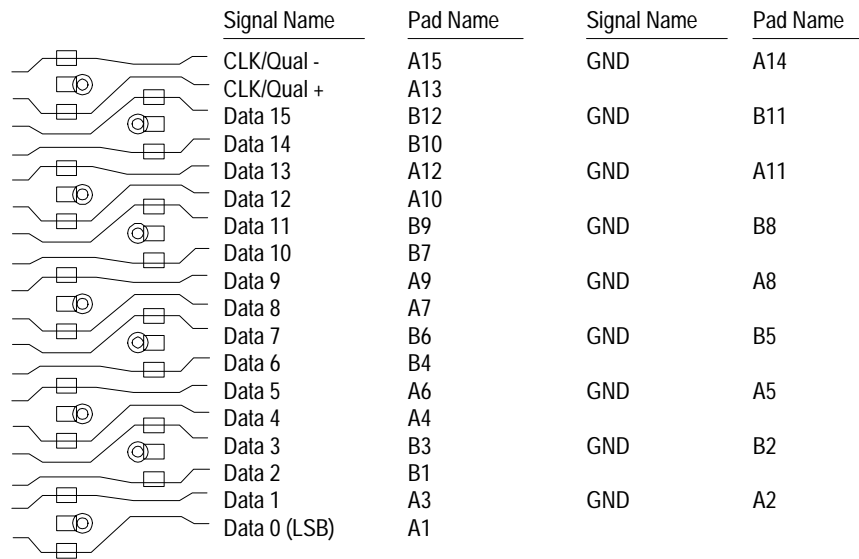

Figure 2-3: High-Density probe land footprint in a typical pass-through signal path layout configuration

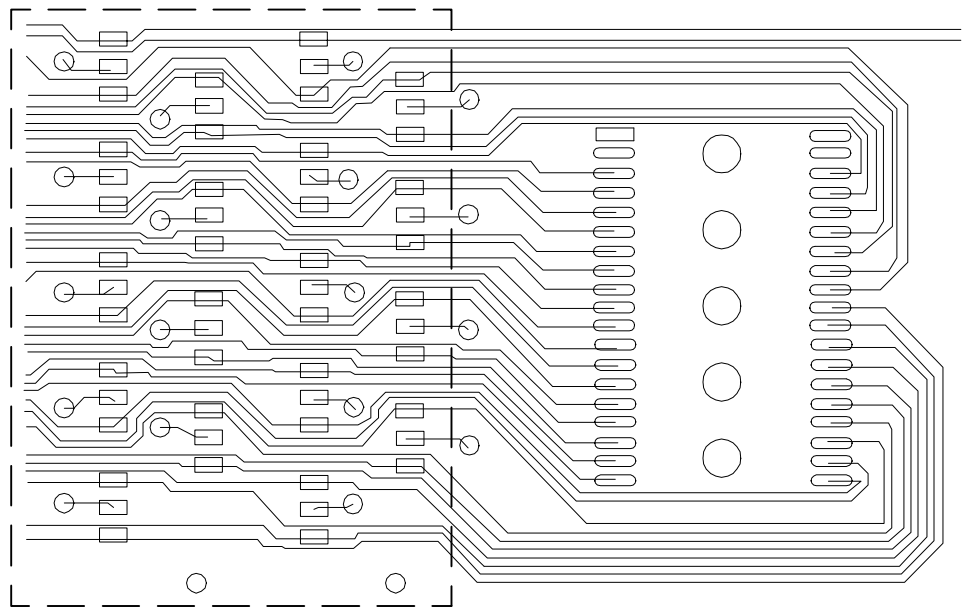

Figure 2-4: Example layouts of the High-Density compression compared to the mictor land footprints

P6880 Differential Probe Land Footprint. See Figure 2-5 for the land footprint for the P6880 High-Density Differential Probe. Figure 2-6 illustrates an example of the High-Density Differential Probe land footprint in a typical pass-through signal path layout configuration.

NOTE. Because the land pattern is the same between P6880 and P6860 probes, you can also use the P6860 probe to look at both sides of the differential signal using two separate input channels on the P6860 probe.

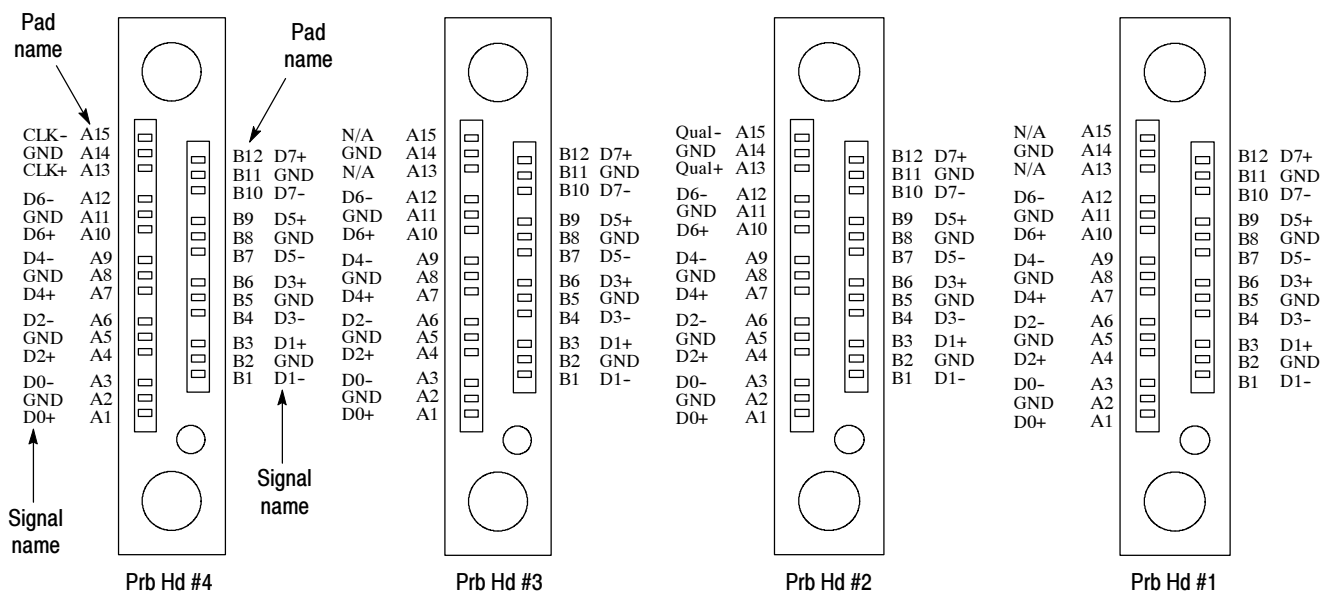

Figure 2-5: P6880 Differential probe land footprint

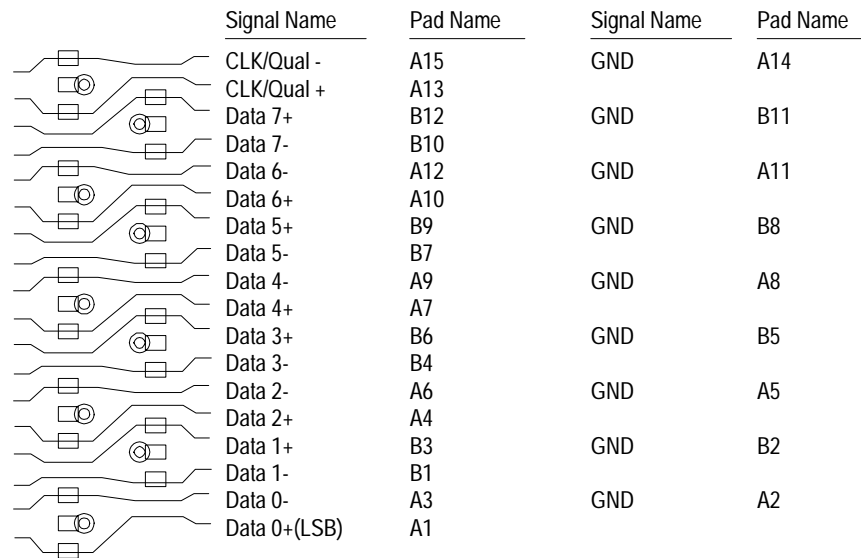

Figure 2-6: High-Density Differential probe land footprint in a typical pass-through signal path layout configuration

Mechanical Considerations

This section provides information on compression land footprint requirements and physical attachment requirements.

The PCB holes, in general, do not have an impact upon the integrity of your signals when the signals routed around the holes have the corresponding return current plane immediately below the signal trace for the entire signal path from driver to receiver.

NOTE. *For optimum signal integrity, there should be a continuous, uninterrupted ground return plane along the entire signal path.*

Land Footprint Requirements for the P6860 and P6880 Probes. See Figure 2-7 for the compression land footprint requirements for the P6860 and P6880 Probes.

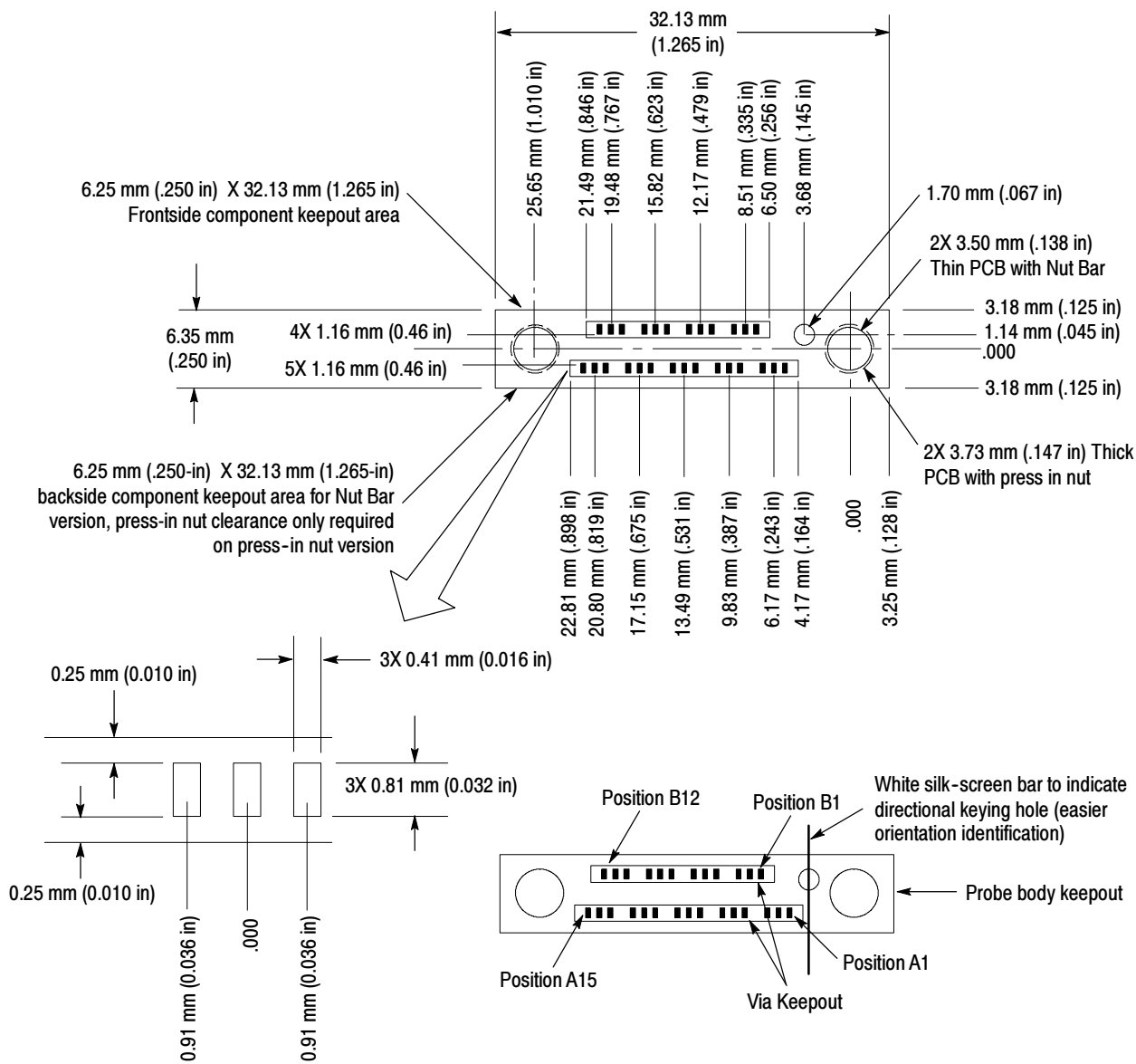

Figure 2-7: Land footprint requirements for the P6860 and P6880 probes (top view)

Special Considerations



WARNING. To avoid personal injury due to electric shock, always turn off the power on your target system before cleaning the compression footprint.

- Cleanliness is important for a reliable connection. Refer to *Cleaning the P6860 and P6880 Compression Footprints*, located on page 1-12.
- Line boxes around the pin groupings are the via keepout areas (not part of the actual land footprint).
- Solder mask is required between all land pads in the component keepout area.
- All signal runs in the keepout areas are required to maintain PCB and solder mask tolerances to ensure that no exposed runs or metal exist between pads. This requirement avoids the risk of shorting signal runs.
- Solder mask hardness of at least 8H (pencil hardness) and thickness of at least 0.0762 mm to 0.1270 mm (0.0003 to 0.0005 in) has been verified for several hundred cycles without appreciable wear from the compression contact cycling.
- The Compression land footprint design was verified on the immersion gold process.

Land Footprint Requirements for the Compression-on-PCB to P6434 Mictor Adapter. See Figure 2-8 for the land footprint requirements for the Compression-on-PCB to P6434 Mictor adapter. This compression adapter converts from the new compression footprint to the existing P6434 Mictor-based 34-channel probe.

Refer to the *P6434 Mass Termination Probe Manual* for the Mictor land footprint specification. Refer to Table 2-12 for the recommended channel mappings for the Compression-on-PCB to P6434 Mictor adapter and Mictor-on-PCB to Compression adapter.

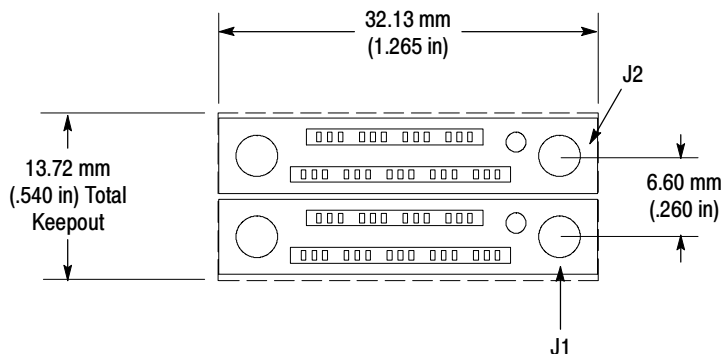

Figure 2-8: Land footprint requirements for the Compression-on-PCB to P6434 Mictor adapter

Special Considerations

- Two compression land footprints must be spaced as per the mechanical dimensions specified to support the compression adapter.
- Placement of the compression land footprints is only constrained with use of the compression adapter, not in normal usage of the TLA7Axx logic analyzer with a High-Density Probe.
- The P6434 Probe and older logic analyzer modules do not support differential signals. Therefore, the compression adapter cannot be used to support differential signals beyond capturing each side of the differential signal independently in a single-ended manner.
- The compression adapter will add capacitance to the P6434 Probe input capacitance. The Mictor adapter adds 2.7 pF to the High-Density Compression probe load of 0.7 pF for a combined adapter capacitance load of 3.4 pF.
- The TLA7Axx logic analyzer with the P6860 High-Density Probe will connect directly to the compression land footprint to support high performance data capture and viewing needs.
- The TLA7Axx logic analyzer with the P6880 High-Density Differential Probe will also connect directly to the compression land footprint to support high performance differential signal capture and viewing needs.

Physical Attachment Requirements for the P6810 Probe. See Figure 2-9 for the physical dimensions of the P6810 General Purpose Probe.

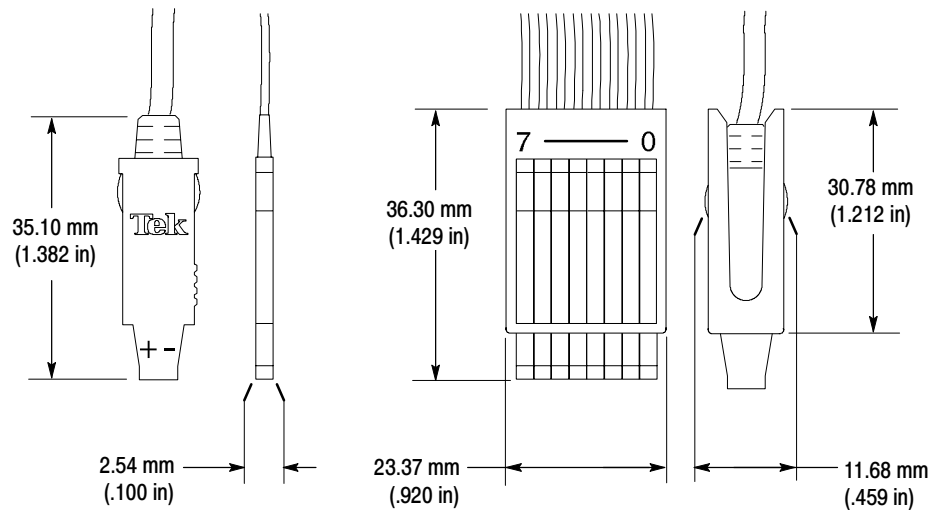

Figure 2-9: Physical attachment requirements for the P6810 probe

Physical Attachment Requirements for the P6860 and P6880 Probes. The connector-less P6860 High-Density Probe and P6880 High-Density Differential Probe interconnects are designed to accommodate PCB thickness ranging from 1.27 mm to 6.35 mm (0.050 in to 0.250 in). To accommodate this range, there are two versions of the design.

- Nut bar
- Press-in nut

If the PCB thickness is 1.27 mm to 2.36 mm (0.050 in to 0.093 in), use the nut bar with the thin elastomer (see Figure 2-10).

If the PCB thickness is 2.36 mm to 6.35 mm (0.093 in to 0.250 in), use the press-in nut with the thick elastomer (see Figure 2-11).

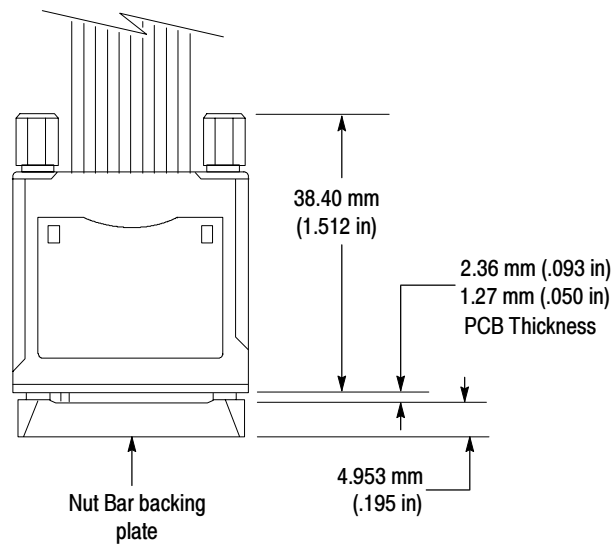

Figure 2-10: Nut Bar design

Special Considerations for the Nut Bar Design

- The nut bar backing plate is required to maintain PCB flatness, which supports the compression connection.
- The nut bar snaps in and out of the PCB without the use of tools.
- Nut bars are reusable and are not required to be a permanent part of the PCB.
- The elastomer used is independent and replaceable.
- Additional nut bars and both thick and thin elastomer holders may be ordered from Tektronix.

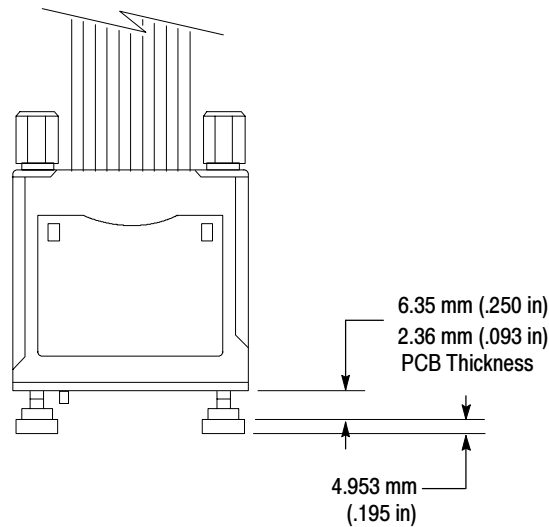

Figure 2-11: Press-in Nut design

Special Considerations for the Press-in Nut Design

- The PEM[®] KF2 2-56 or equivalent press-in nut must be inserted into the PCB.
- The elastomer used is independent and replaceable.

Physical Attachment Requirements for the Compression-on-PCB to P6434 Mictor and Mictor-on-PCB to P6860 Compression Adapters. See Figure 1-5 on page 1-8 and Figure 1-6 on page 1-9 for the mechanical dimensions of the adapters.

Electrical Considerations

This section provides information on transmission lines and load models for the P6810 General Purpose, P6860 High-Density, and P6880 High-Density Differential Probes.

The low frequency model is typically adequate for rise and fall times of 1 ns or greater in a typical 25 Ω source impedance environment (50 Ω runs with a pass-through connection). For source impedance outside this range, and/or rise and fall times less than 1 ns, use the high frequency model to determine if a significant difference is obtained in the modeling result.

The compression land pattern pad is not part of the load model. Make sure that you include the compression land pad and in the modeling.

Transmission Lines. Due to the high performance nature of the interconnect, ensure that stubs, which are greater than 1/4 length of the signal rise time, be modeled as transmission lines.

P6810 General Purpose Probe Load Model. The following electrical model (see Figure 2-12) displays a single podlet load model of the General Purpose Probes.

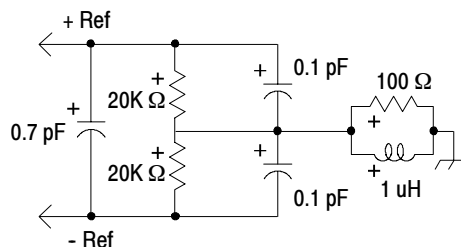

Figure 2-12: Single podlet load model

The characteristics listed in Table 2-15 apply to all kit connectors unless otherwise noted.

Table 2-15: Characteristics

| | |
|---------------------|--|
| Recommended usage | TTL and CMOS levels only. Ground leads should be connected to ground of system under test. Not recommended for signals with edge rates > 1 V/ns. |
| Maximum clock speed | 50 MHz |
| AC loading | < 5 pF per channel as seen by the device under test (plus podlet) |
| DC loading | None |
| Termination | Each signal lead on the eight-channel leadset contains a 150 Ω series termination near the end of the barrel connector to minimize signal reflections. |
| Dimensions | See Figures 2-13 and 2-14 on page 2-34. |

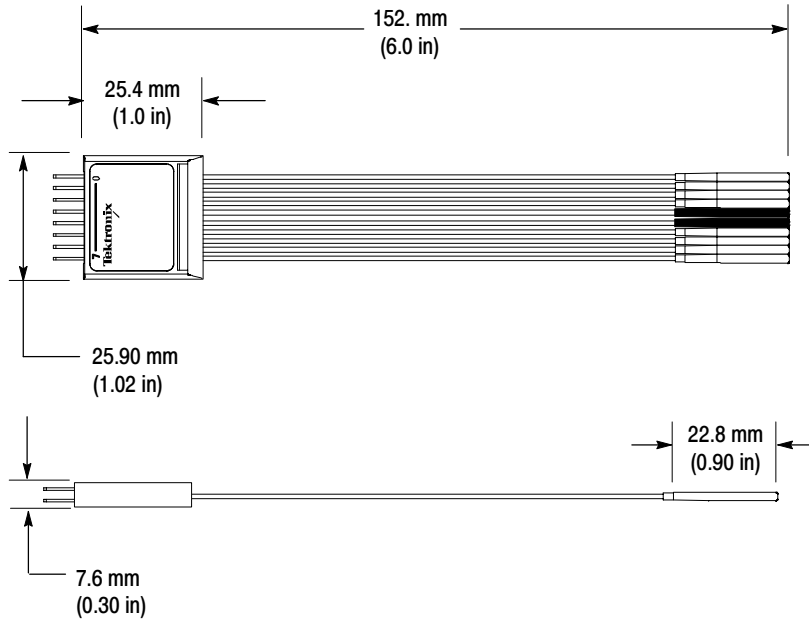

Figure 2-13: Eight-channel leadset (barrel connectors)

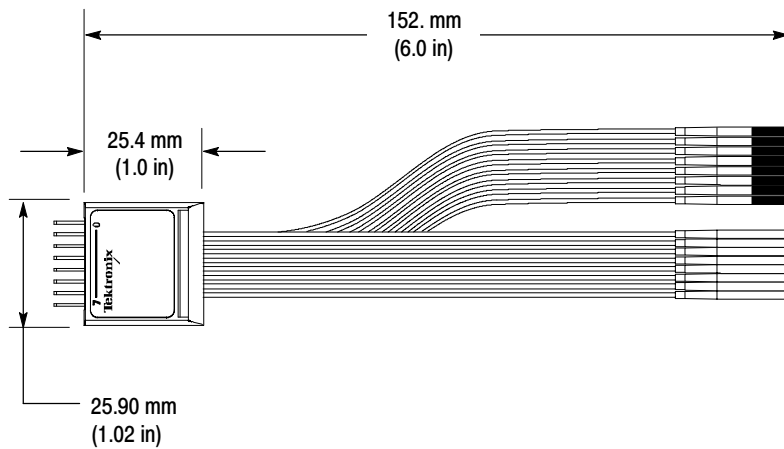

Figure 2-14: Eight-channel differential leadset

P6860 High-Density and P6880 High-Density Differential Probes Load Model. The following electrical model (see Figure 2-15) includes a low-frequency and high-frequency model of the High-Density and High-Density Differential Probes. For the Differential Probe, the load model is applied to both the + side and the - side of the signal.

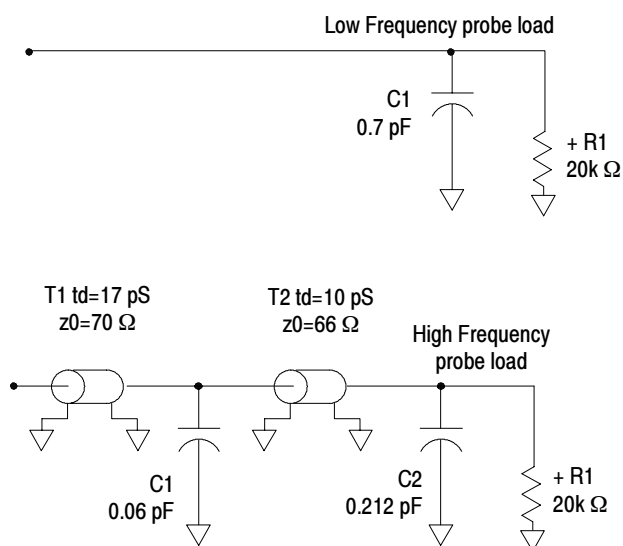

Figure 2-15: High-Density and High-Density Differential probe load model

The differential load for the P6860 clock input and the P6880 probe can be modeled by attaching the single line model to each side (+ and -) of the differential signal. The + and - sides of the differential signal are well insulated in the probe head up to and including the differential input stage.

Mictor-on-PCB to P6860 Compression Adapter Load Model. Refer to Figure 2-16 for an electrical model of the Mictor-on-PCB to P6860 Compression adapter. The pad cap is the capacitance of the 0.016 in x 0.032 in pad of the P6860/P6880 compression land footprint. The capacitive load depends upon the distance to the underlying conductors.

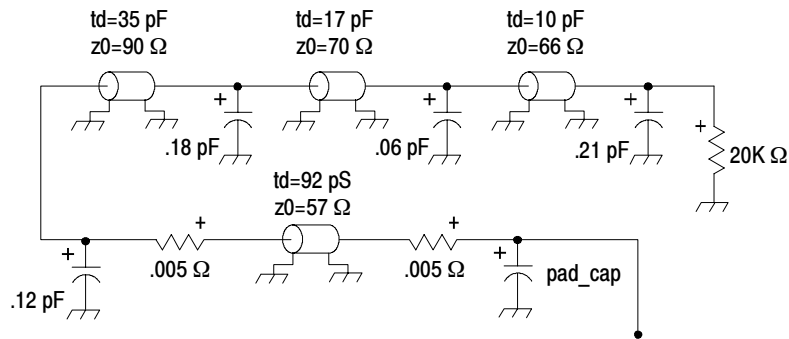

Figure 2- 16: Mictor-on-PCB to Compression adapter load model

Compression-on-PCB to P6434 Mictor Adapter Load Model. Refer to Figure 2-17 for an electrical model of the Compression-on-PCB to P6434 Mictor adapter. The pad cap is the capacitance of the 0.016 in x 0.032 in pad of the P6860/P6880 compression land footprint. The capacitive load depends upon the distance to the underlying conductors.

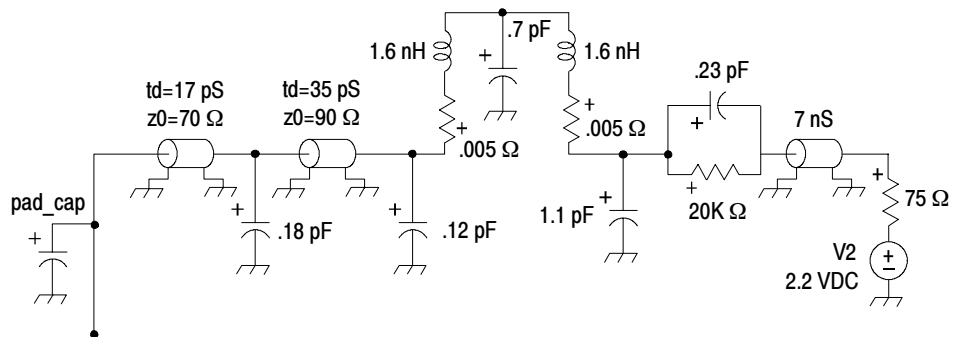

Figure 2- 17: Compression-on-PCB to P6434 Mictor adapter load model



Specifications

Specifications

Mechanical and Electrical Specifications

Table 3-1 lists the electrical and mechanical specifications for the P6810, P6860, and P6880 Probes. The electrical specifications apply when the probe is connected between a compatible logic analyzer and a target system.

Refer to the *Tektronix Logic Analyzer Family User Manual* for a complete list of specifications, including overall system specifications.

Table 3-1: Electrical and mechanical specifications

| Characteristic | P6810 | P6860 | P6880 |
|--|--|--|--|
| Threshold accuracy | $\pm (35 \text{ mV} \pm 1\% \text{ of setting})$ | $\pm (35 \text{ mV} \pm 1\% \text{ of setting})$ | $\pm (35 \text{ mV} \pm 1\% \text{ of setting})$ |
| Input resistance | $20 \text{ k}\Omega \pm 1\%$ | $20 \text{ k}\Omega \pm 1\%$ | $20 \text{ k}\Omega \pm 1\%$ |
| Input capacitance | $<1.0 \text{ pF}$ | 0.7 pF (typical) | 0.7 pF (typical) |
| Minimum digital signal swing | 300 mV single-ended | 300 mV single-ended | 150 mV differential each side |
| Maximum nondestructive input signal to probe | $\pm 15 \text{ V}$ | $\pm 15 \text{ V}$ | $\pm 15 \text{ V}$ |
| Delay from probe tip to module input connector | $7.70 \text{ ns} \pm 80 \text{ ps}$ | $7.70 \text{ ns} \pm 60 \text{ ps}$ | $7.70 \text{ ns} \pm 80 \text{ ps}$ |
| Probe length | 1.8 m (6 ft) | 1.8 m (6 ft) | 1.8 m (6 ft) |
| Operating range | +5 V to -2.5 V | +5 V to -2.5 V | +5 V to -2.5 V |

NOTE. Because the length of all three probes are electrically similar, they can be interchanged without problems.

Single podlet input capacitance is 0.7 pF, but podlets in a group will have 1 pF input capacitance.

Table 3-2 shows the environmental specifications for all three probes. The probes are designed to meet Tektronix standard 062-2847-00 class 5.

Table 3-2: Environmental specifications

| Characteristic | P6810 | P6860 | P6880 |
|------------------------|---|---|---|
| Temperature | | | |
| Operating | 0 °C to + 50 °C | 0 °C to + 50 °C | 0 °C to + 50 °C |
| Non-operating | - 51 °C to 71 °C | - 51 °C to 71 °C | - 51 °C to 71 °C |
| Humidity | 10 °C to 30 °C 95% relative humidity | 10 °C to 30 °C 95% relative humidity | 10 °C to 30 °C 95% relative humidity |
| | 30 °C to 40 °C 75% relative humidity | 30 °C to 40 °C 75% relative humidity | 30 °C to 40 °C 75% relative humidity |
| | 40 °C to 50 °C 45% relative humidity | 40 °C to 50 °C 45% relative humidity | 40 °C to 50 °C 45% relative humidity |
| Altitude | | | |
| Operating | 10,000 ft (3,048 m) | 10,000 ft (3,048 m) | 10,000 ft (3,048 m) |
| Non-operating | 40,000 ft (12,192 m) | 40,000 ft (12,192 m) | 40,000 ft (12,192 m) |
| Electrostatic immunity | 6 kV | 6 kV | 6 kV |



Maintenance

Maintenance

The P6810, P6860, and P6880 Probes do not require scheduled or periodic maintenance. Refer to the Functional Check section (page 4-1) to verify the basic functionality of the probes.

To confirm that the probes meet or exceed the performance requirements for published specifications with a compatible logic analyzer module, refer to the *TLA7Axx Logic Analyzer Module Service Manual* and follow the procedures listed under performance verification procedures.

Probe Calibration

If performing the probe calibration yourself, refer to the *TLA7Axx Logic Analyzer Module Service Manual* for the complete calibration procedure. Otherwise, return the probe to the local Tektronix service center.

Service Strategy

Except for the elastomer holders, the P6810, P6860, and P6880 Probes contain no user-replaceable parts. If probe failure occurs, return the entire probe to your Tektronix service representative for repair.

Functional Check

NOTE. For the default setup if you connect probes to any channels other than the A2 and A3 groups, you must define the groups and channels in the Setup window before acquiring data on other probe channels.

Connect the logic analyzer probes to a signal source, start an acquisition, and verify that the acquired data is displayed in either the listing or waveform windows.

If available, use the TLACAL2 fixture to run the performance verification. For further details, refer to the performance verification procedure in the *TLA7Axx Logic Analyzer Module Service Manual*.

Inspection and Cleaning



CAUTION. *To prevent damage during the probe connection process, do not touch the exposed edge of the elastomer.*

To maintain a reliable electrical contact, keep the probes free of dirt, dust, and contaminants. Remove dirt and dust with a soft brush. For more extensive cleaning, use only a damp cloth. Never use abrasive cleaners or organic solvents.

Repackaging Instructions

Use the original packaging, if possible, to return or store the probes. If the original packaging is not available, use a corrugated cardboard shipping carton. Add cushioning material to prevent the probes from moving inside the shipping container.

Enclose the following information when shipping the probe to a Tektronix Service Center.

- Owner's address
- Name and phone number of a contact person
- Type of probe
- Reason for return
- Full description of the service required



Replaceable Parts

Replaceable Parts

This chapter contains a list of the replaceable components for the P6810, P6860 and P6880 Probes. Use this list to identify and order replacement parts.

Parts Ordering Information

Replacement parts are available through your local Tektronix field office or representative.

Changes to Tektronix products are sometimes made to accommodate improved components as they become available and to give you the benefit of the latest improvements. Therefore, when ordering parts, it is important to include the following information in your order.

- Part number
- Instrument type or model number
- Instrument serial number
- Instrument modification number, if applicable

If you order a part that has been replaced with a different or improved part, your local Tektronix field office or representative will contact you concerning any change in part number.

Using the Replaceable Parts List

Replaceable Parts

The P6810 probe contains no user-replaceable parts, while the P6860 and P6880 compression probes contain only the elastomer as a replaceable part. If probe failure occurs, return the entire probe to your Tektronix service representative for repair.

Refer to the following list for replaceable items:

Parts list column descriptions

| Column | Column name | Description |
|---------|-----------------------|--|
| 1 | Figure & index number | Items in this section reference figure and index numbers to the exploded view illustrations that follow. |
| 2 | Tektronix part number | Use this part number when ordering replacement parts from Tektronix. |
| 3 and 4 | Serial number | Column three indicates the serial number at which the part was first effective. Column four indicates the serial number at which the part was discontinued. No entries indicates the part is good for all serial numbers. |
| 5 | Qty | This indicates the quantity of parts used. |
| 6 | Name & description | An item name is separated from the description by a colon (:). Because of space limitations, an item name may sometimes appear as incomplete. Use the U.S. Federal Catalog handbook H6-1 for further item name identification. |
| 7 | Mfr. code | This indicates the code of the actual manufacturer of the part. |
| 8 | Mfr. part number | This indicates the actual manufacturer's or vendor's part number. |

Abbreviations Abbreviations conform to American National Standard ANSI Y1.1-1972.

Mfr. Code to Manufacturer Cross Index The table titled Manufacturers Cross Index shows codes, names, and addresses of manufacturers or vendors of components listed in the parts list.

Manufacturers cross index

| Mfr. code | Manufacturer | Address | City, state, zip code |
|-----------|---------------|--------------------------------------|--------------------------|
| 80009 | TEKTRONIX INC | 14150 SW KARL BRAUN DR PO BOX 500 | BEAVERTON, OR 97077-0001 |

P6810 replaceable parts list

| Figure & index number | Tektronix part number | Serial no. effective | Serial no. discont'd | Qty | Name & description | Mfr. code | Mfr. part number |
|-----------------------------------|-----------------------|----------------------|----------------------|-----|--|-----------|------------------|
| 5-1 | | | | | | | |
| -1 | 010-6810-10 | | | 1 | GENERAL PURPOSE PROBE (INCLUDES SHEET OF LABELS AND LABELING INSTRUCTIONS) | 80009 | 010-6810-10 |
| -6 | 352-1097-00 | | | 4 | PODLET HOLDER | 80009 | 352-1097-00 |
| P6810 STANDARD ACCESSORIES | | | | | | | |
| -2 | 196-3471-00 | | | 2 | P6810 LEADSET, 1 CH SINGLE-ENDED AND DIFFERENTIAL | 80009 | 196-3471-00 |
| -3 | 196-3470-00 | | | 4 | P6810 LEADSET, 8 CH SINGLE-ENDED | 80009 | 196-3470-00 |
| -4 | 196-3472-00 | | | 4 | P6810 LEADSET, 8 CH DIFFERENTIAL | 80009 | 196-3472-00 |
| -5 | SMG50 | | | 2 | ADAPTER KIT; BAG OF 20 KLIPCHIP ADAPTER (40 TOTAL) | 80009 | SMG50 |
| | 071-1059-00 | | | 1 | MANUAL, TECH:INSTRUCTIONS, P6810, P6860, & P6880 | 80009 | 071-1059-00 |
| | 071-1122-00 | | | 1 | MANUAL, TECH; INSTRUCTIONS, P6810 GENERAL PURPOSE LOGIC ANALYZER PROBE LABEL | 80009 | 071-1122-00 |
| | 335-0345-00 | | | 1 | P6810 PROBE, SHEET OF LABELS | 80009 | 335-0345-00 |

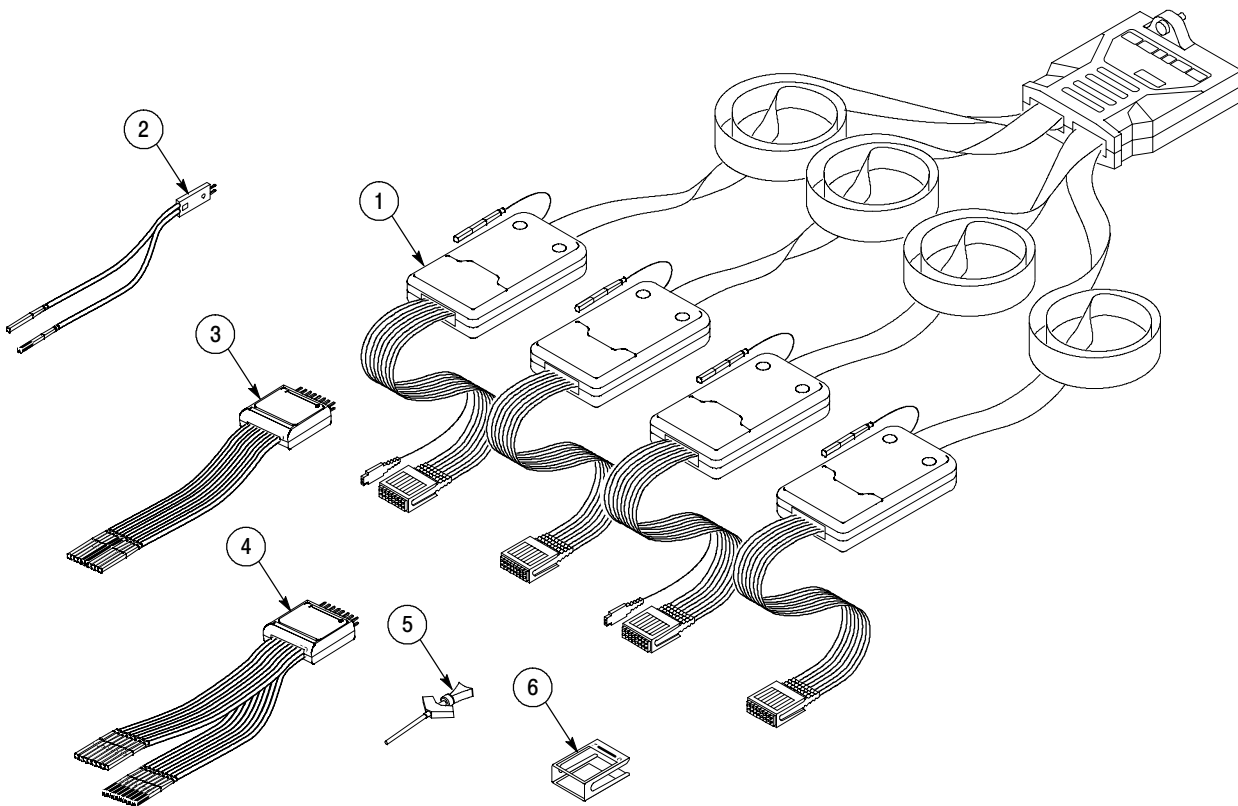

Figure 5-1: P6810 General Purpose probe accessories

P6860 replaceable parts list

| Figure & index number | Tektronix part number | Serial no. effective | Serial no. discont'd | Qty | Name & description | Mfr. code | Mfr. part number |
|-----------------------|-----------------------|----------------------|----------------------|-----|---|-----------|------------------|
| 5-2 | | | | | | | |
| -1 | 010-6860-10 | | | 1 | P6860 PROBE (INCLUDES SHEET OF LABELS AND PROBE LABELING INSTRUCTIONS) | 80009 | 010-6860-10 |
| | | | | | P6860 STANDARD ACCESSORIES | | |
| -2 | 020-2451-00 | | | 2 | P6860 THIN ELASTOMER HOLDER ASSEMBLY, (USED WITH NUT BAR), BAG OF 2 (BLACK) (TOTAL OF 4 ELASTOMER ASSEMBLIES) | 80009 | 020-2451-00 |
| -3 | 020-2452-00 | | | 2 | P6860 THICK ELASTOMER HOLDER ASSEMBLY, (USED WITH PRESS-IN NUTS), BAG OF 2 (GRAY) (TOTAL OF 4 ELASTOMER ASSEMBLIES) | 80009 | 020-2452-00 |
| | 071-1059-00 | | | 1 | MANUAL, TECH:INSTRUCTIONS, P6810, P6860, & P6880 | 80009 | 071-1059-00 |
| | 071-1123-00 | | | 1 | MANUAL, TECH; INSTRUCTIONS, P6860 HIGH DENSITY LOGIC ANALYZER PROBE LABEL | 80009 | 071-1123-00 |
| | 335-0346-00 | | | 1 | P6860 PROBE, SHEET OF LABELS | 80009 | 335-0346-00 |
| | 061-4254-00 | | | 1 | DATA SHEET; READ THIS FIRST, PRECAUTIONS FOR HANDLING ELASTOMER BASED COMPRESSION PROBES,GOLDEN ROD;DP | 80009 | 061-4254-00 |

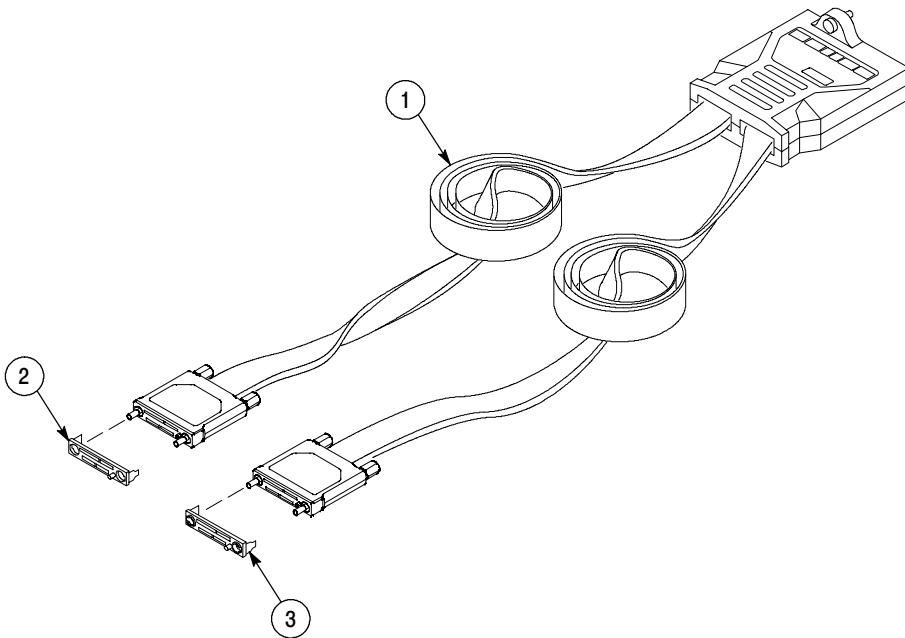

Figure 5-2: P6860 High-Density probe accessories

P6880 replaceable parts list

| Figure & index number | Tektronix part number | Serial no. effective | Serial no. discont'd | Qty | Name & description | Mfr. code | Mfr. part number |
|-----------------------|-----------------------|----------------------|----------------------|-----|--|-----------|------------------|
| -5-3 | | | | | | | |
| -1 | 010-6880-10 | | | 1 | P6880 PROBE SET (INCLUDES SHEET OF LABELS AND PROBE LABELING INSTRUCTIONS) | 80009 | 010-6880-10 |
| | | | | | P6880 STANDARD ACCESSORIES | | |
| -2 | 020-2451-00 | | | 4 | P6880 THIN ELASTOMER HOLDER ASSEMBLY, (USED WITH THE NUTBLOCK), BAG OF 2 (BLACK) (TOTAL OF 8 ELASTOMER ASSEMBLIES) | 80009 | 020-2451-00 |
| -3 | 020-2452-00 | | | 4 | P6880 THICK ELASTOMER HOLDER ASSEMBLY, (USED WITH THE PRESS-IN NUTS), BAG OF 2 (TEK SILVER GRAY). TOTAL OF 8 ELASTOMER ASSEMBLIES. | 80009 | 020-2452-00 |
| | 071-1059-00 | | | 1 | MANUAL, TECH:INSTRUCTION, P6810, P6860, & P6880 | 80009 | 071-1059-00 |
| | 071-1124-00 | | | 1 | MANUAL, TECH; INSTRUCTIONS, P6880 HIGH DENSITY DIFFERENTIAL LOGIC ANALYZER PROBE LABEL | 80009 | 071-1124-00 |
| | 335-0697-00 | | | 1 | SHEET OF LABELS, P6880 PROBE | 80009 | 335-0697-00 |
| | 061-4254-00 | | | 1 | DATA SHEET; READ THIS FIRST, PRECAUTIONS FOR HANDLING ELASTOMER BASED COMPRESSION PROBES,GOLDEN ROD;DP | 80009 | 061-4254-00 |

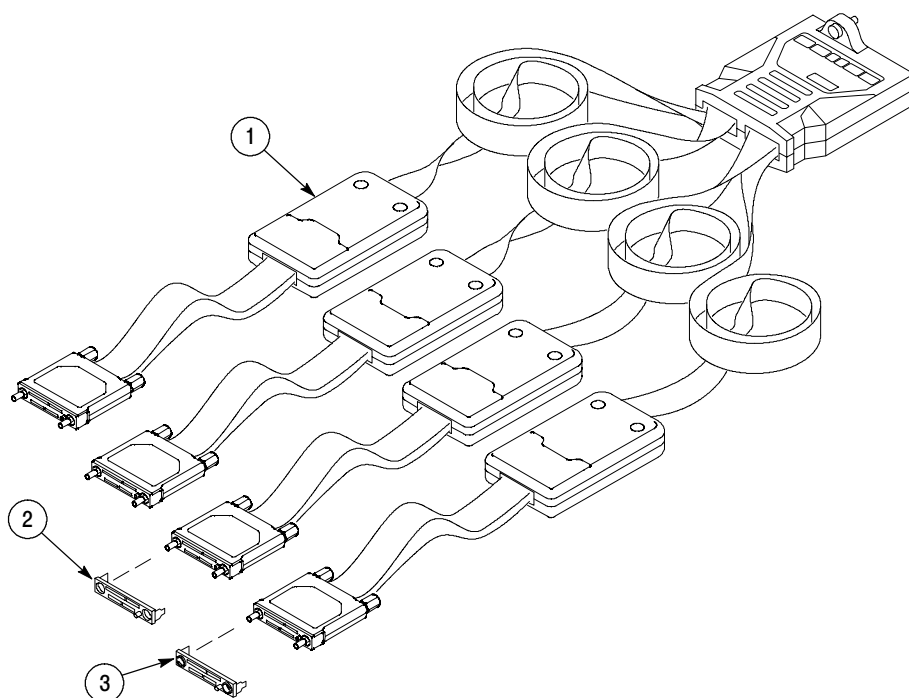

Figure 5-3: P6880 High-Density Differential probe accessories

P6860 replaceable parts list

| Figure & index number | Tektronix part number | Serial no. effective | Serial no. discontinued | Qty | Name & description | Mfr. code | Mfr. part number |
|-----------------------|-----------------------|----------------------|-------------------------|-----|--|-----------|------------------|
| 5-4 | | | | | P6860 and P6880 OPTIONAL ACCESSORIES | | |
| -1 | 020-2453-00 | | | 1 | NUT BAR ASSEMBLY, BAG OF 2 | 80009 | 020-2453-00 |
| -2 | 020-2455-00 | | | 1 | 17 CH COMPRESSION-ON-PCB TO P6434 MICTOR ADAPTER | 80009 | 020-2455-00 |
| -3 | 020-2456-00 | | | 1 | 34 CH COMPRESSION-ON-PCB TO P6434 MICTOR ADAPTER | 80009 | 020-2456-00 |
| -4 | 020-2457-00 | | | 1 | 34 CH MICTOR-ON-PCB TO P6860 COMPRESSION ADAPTER | 80009 | 020-2457-00 |
| -5 | 352-1095-00 | | | 1 | ELASTOMER ASSEMBLY | 80009 | 352-1095-00 |

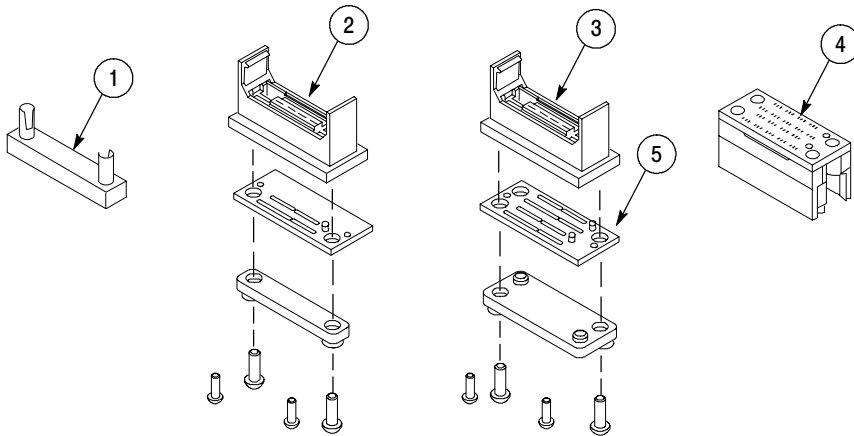

Figure 5-4: Optional accessories



Index

Index

Numbers

- 1-Channel single-ended and differential leadset, 1-3
- 8-Channel single-ended and differential leadset, 1-3
- 8-Channel differential leadset, 1-3

A

Adapters

- Compression on PCB to Mictor, 1-8
- definition of, xi
- Mictor on PCB to Compression, 1-7

C

Calibration, probe, 4-1

Cleaning

- compression footprints, 1-12
- inspection and, 4-2
- probe heads, 1-12

Clocking, Source Synchronus*, 2-3

Clocks, 2-1

Commonly used terms, x

Compression footprint, x

Compression on PCB to Mictor adapter, 1-8

Connecting

- probes to logic analyzer, 1-11
- probes to target system, 1-14

Contacting Tektronix, xii

D

Designing an interface, 2-1

- electrical considerations, 2-32
- land footprints, 2-21
- mechanical considerations, 2-26
- signal names, 2-6

Differential input amplitude definition, x

Documentation, related, ix

E

Elastomer holder, 1-16

- installing Nutblock, 1-16
- installing Press-in nuts, 1-16

Electrical considerations

- Compression-on-PCB to P6434 Mictor adapter, 2-36

Mictor-on-PCB to Compression adapter, 2-35

P6810 General Purpose Probe load model, 2-33

P6860 High Density Probe and P6880 High Density Differential Probe load model, 2-35

Transmission lines, 2-32

F

Footprints, land, 2-21

P6810 General Purpose Probe, 2-21

P6860 High Density Probe, 2-23

P6880 High Density Differential Probe, 2-25

Functional check, x, 4-1

G

General Purpose Probe, P6810, 1-1

H

Help, Online, ix

High Density Differential Probe, P6880, 1-6

High Density Probe, P6860, 1-4

High resolution timing modes, 2-5

Holder, podlet, xi

I

Inspection and cleaning, 4-2

Installing, elastomer holder, 1-16

K

Keepout area, x, 2-27, 2-29

L

Land footprints, 2-21

P6810 General Purpose Probe, 2-21

P6860 High Density Probe, 2-23

P6880 High Density Differential Probe, 2-25

Leadsets, 1-3

Load model

Compression-on-PCB to P6434 Mictor adapter, 2-36

Mictor-on-PCB to Compression adapter, 2-35

P6810 General Purpose Probe, 2-33

P6860 High Density Probe and P6880 High Density
Differential Probe, 2-35
Logic analyzer, connecting probes, 1-11

M

Maintenance, 4-1
 functional check, 4-1
 inspection and cleaning, 4-2
 probe calibration, 4-1
 repackaging instructions, 4-2
 service strategy, 4-1
Mechanical considerations
 land footprint requirements for the Compression on
 PCB to Mictor adapter, 2-28
 land footprint requirements for the P6860 and P6880
 Probes, 2-26
 physical attachment requirements for P6810 Probe,
 2-29
 physical attachment requirements for P6860 and
 P6880 Probes, 2-30
 physical attachment requirements for the Compression on PCB to Mictor and Mictor on PCB to
 Compression adapters, 2-32
Merged module, 2-3
Mictor on PCB to Compression adapter, 1-7
Module, x

N

Nutblock, 1-16

O

Online Help, ix
Online Release Notes, ix
Ordering parts information, 5-1

P

Parts
 ordering information, 5-1
 TLA700 Series, 5-3
 using the replaceable parts list, 5-1
PCB (printed circuit board), xi
Phone number, Tektronix, xii
Podlet, xi
Podlet holder, xi
Press-in nuts, 1-16
Probes

adapter, definition of, xi
calibration, 4-1
cleaning the P6860 and P6880 Compression
 footprints, 1-12
cleaning the P6860 and P6880 probe heads, 1-12
connecting probes to the logic analyzer, 1-11
connecting probes to the target system, 1-14
definition of, xi
head, definition of, xi
P6810 General Purpose Probe, 1-1
P6860 High Density Probe, 1-4
P6880 High Density Differential Probe, 1-6
product description, 1-1
returning, 4-2
storing, 4-2
Probing analog signals, 2-6
Product description
 Compression on PCB to Mictor adapter, 1-8
 Mictor on PCB to Compression adapter, 1-7
 P6810 Leadset adapters and accessories, 1-3
 P6860 High Density Probe, 1-4
 P6880 High Density Differential Probe, 1-6
Product support, contact information, xii

Q

Qualifiers, 2-1

R

Range recognition, 2-6
Related documentation, ix
Release Notes, online, ix
Repackaging instructions, 4-2
Replaceable parts list, 5-3
Requirements
 land footprint for the Compression on PCB to Mictor
 adapter, 2-28
 land footprints for the P6860 and P6880 Probes,
 2-26
 physical attachment for the Compression on PCB to
 Mictor and Mictor on PCB to Compression
 adapters, 2-32
 physical attachment for the P6810 Probe, 2-29
 physical attachment for the P6860 and P6880
 Probes, 2-30
Returning probes, 4-2

S

Service strategy, 4-1
Service support, contact information, xii
Signal connections, 2-1
Signal fixturing, 2-1
Signal names, 2-6
SMT KlipChip, xii
Storing probes, 4-2

T

Target system, connecting probes, 1-14
Technical support, contact information, xii
Tektronix, contacting, xii
Terms, commonly used, x

Timing modes, High resolution, 2-5
Transmission Lines, 2-32

U

URL, Tektronix, xii

W

Way station, xii
Web site address, Tektronix, xii

Z

Z-axis elastomer, xii

